

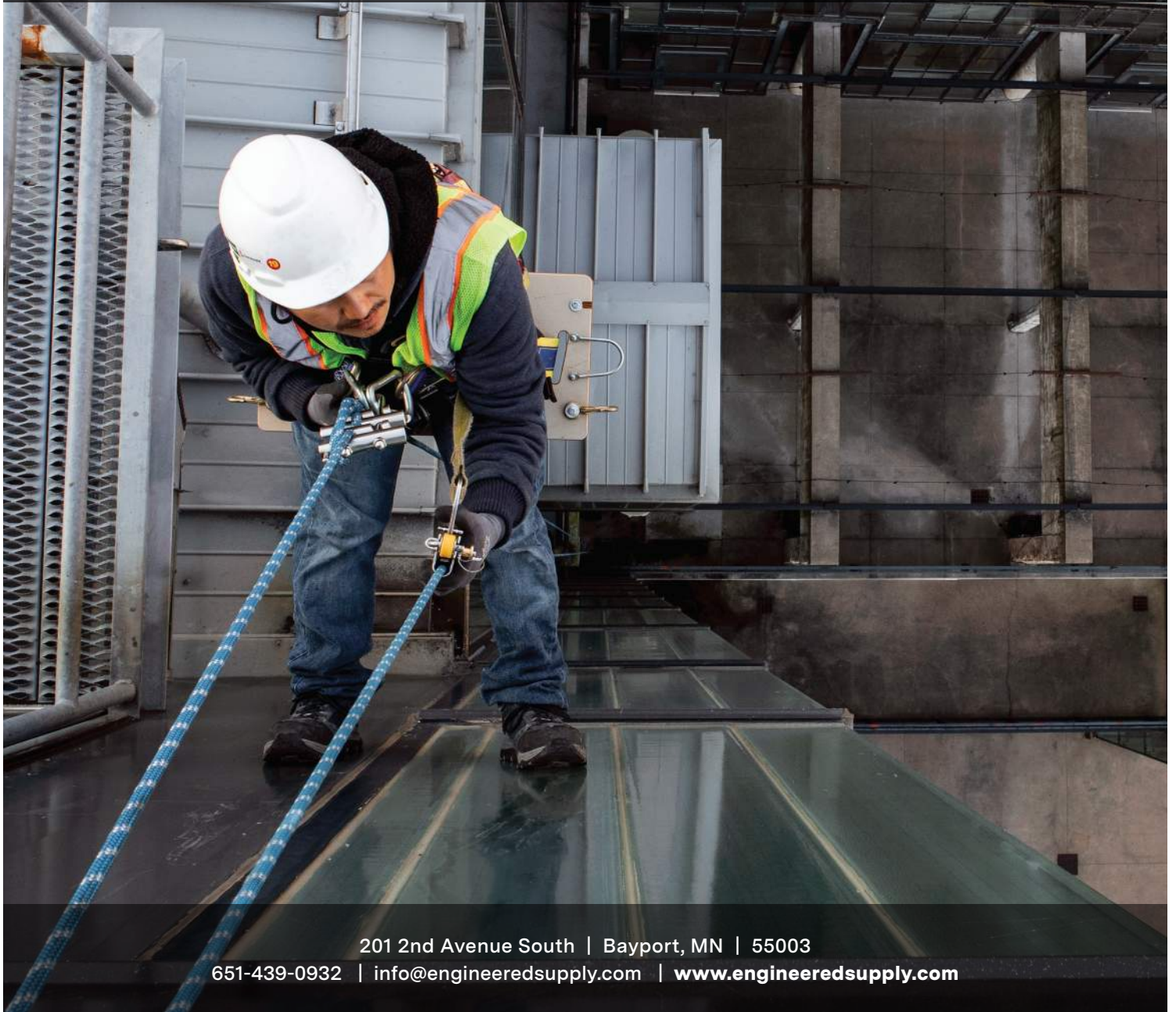

**ENGINEERED
SUPPLY®**

2025 EQUIPMENT MANUAL

SUSPENDED MAINTENANCE ANCHORAGE CONNECTORS



201 2nd Avenue South | Bayport, MN | 55003
651-439-0932 | info@engineeredsupply.com | www.engineeredsupply.com



**ENGINEERED
SUPPLY®**

EQUIPMENT MANUAL

SUSPENDED MAINTENANCE ANCHORAGE CONNECTORS

TABLE OF CONTENTS

.....

System Design	PAGE S1
Anchorage Connectors	PAGE A1
Layout	PAGE L1
Testing and Documentation	PAGE T1
Data Sheets and Installation Details	PAGE D1

DISCLAIMERS

This equipment manual was developed to document current best practices and enhance the health and safety of those involved in suspended maintenance and fall protection using anchorage connectors.

Engineered Supply and the employees of Engineered Supply assume no liability, and in no event shall Engineered Supply or the employees of Engineered Supply be named liable, in whole or in part, for any loss or damage, whether ordinary, special, incidental or consequential, which may occur or be named as a result of the use or misuse of the information in this Equipment Manual.

In recognition of the relative risks, rewards and benefits of the project to both the Client and Engineered Supply, the risks have been allocated so that the Client agrees that, to the fullest extent permitted by law, Engineered Supply's total liability to the Client, for any and all injuries, claims, losses, expenses, damages or claim expenses arising out of this agreement, from any cause or causes, shall not exceed five times the amount received by Engineered Supply for the given scope of work. Such causes include, but are not limited to, Engineered Supply's negligence, errors, omissions, strict liability, breach of contract or breach of warranty.

COPYRIGHT

Copyright © 2024 Engineered Supply. All Rights Reserved. Printed in the U.S.A. Reproduction of these materials in any format be it verbal, written, electronic or computerized is strictly prohibited without the expressed written consent of Engineered Supply.

FOREWORD

This Equipment Manual provides requirements of anchorage connector layout, design, and use. This manual does not change any other requirements. The user is to comply with the most restrictive requirement applicable to the given situation.

Suspended maintenance anchorage connectors and their usage are governed by the applicable law. In the United States this is primarily the Occupational Safety and Health Administration (OSHA), a large regulatory agency of the U.S. Department of Labor. These laws are broad and meant to cover a wide range of methods, and typically rely on manufacturers, industry specific standards, employers, and users to determine details.

Individual states (such as California, Minnesota, New York, and Washington) have additional requirements for suspended maintenance anchorage connectors in their state regulations and building codes. If there is not a recognized standard building code with appropriate referenced standards legislatively in place for building construction at the project's location, it is acceptable to use the latest edition of the International Building Code (IBC) and its referenced standards, the latest edition of the IWCA 114.1, and the Z359 code family for anchorage connector rating as a basis of design.

There are two recognized paths to compliant anchorage connector strength and anchorage connector attachment hardware strength: 1) calculations based on standardized building codes and their referenced standards using defined materials within the bounds of their scope and 2) testing completed based on standardized codes and their referenced standards using defined materials within the bounds of the scope. The primary and secondary supporting structure has one recognized path to compliance: 1) through calculations based on standardized building codes and their referenced standards using defined materials within the bounds of their scope. Field inspection, and additional testing in the shop and field, is completed to verify the installation is correct and is not a replacement for manufacturer product ratings and structural calculations as judged appropriate by the project's Professional Engineer.

The current basis for shop testing of manufactured suspended maintenance anchorage connectors is the ANSI Z359.18-T. Note that the ANSI Z359.18-T minimum breaking strength of 5,000 pounds determined by testing is compliant with the U.S. Department of Labor and regularly accepted by engineers and AHJs, however it is a different rating than having a 5,000 pound design strength, which is often required by the IBC or by some jurisdictions through their local occupational health departments (such as CalOSHA's specific anchorage connector requirements). The intent of this manual is to require new anchorage connectors used for suspended maintenance to comply with both the locally applicable building code and when manufactured in batch quantities to comply with the Z359.18-T standard and the applicable building code, while allowing existing legacy anchorage connectors that are compliant with OSHA and other applicable legislative requirements to remain in use until the lifespan is complete and are then to be replaced with fully compliant anchorage connectors.

Building codes often have additional requirements that must be met during building construction, which are governed by the building permitting process. There are existing systems that are in compliance with all applicable OSHA requirements that are acceptable for continued use, but are not in compliance with building codes and therefore will need to be replaced with new systems compliant with building codes when their lifespan is complete or major renovation is completed. Existing legacy systems that were certified within the last 11 years are grandfathered in and may continue to be used provided they comply with all applicable OSHA and legislative use requirements as determined by the project's Professional Engineer (no part of a system shall be used that is not in compliance with the applicable use laws, commonly standards from OSHA in the USA).

As individual project requirements rely on a changing mixture of OSHA, Building Code, Manufacturer, Employer, and User standards Engineered Supply requires a minimum competency of having an experienced professional engineer provide a posted Log Book to communicate the applicable standards and appropriate system usage for all Suspended Maintenance Systems. Fall Protection Systems may be designed by a competent qualified person or an experienced professional engineer.

This manual endeavors to provide appropriately designed systems, the information required to appropriately use the system, and assist the project's Professional Engineer or Competent Qualified Person to provide standardized and compliant anchorage connector layouts, anchorage connectors specifications, and ultimately a log book to convey the applicable information to the system User and provide a reference for potential future system modifications.

This manual was initiated and developed by Engineered Supply when it became apparent that there is a need for additional information for anchorage connector layout and design in the suspended maintenance industry. Due consideration shall be given toward implementation of methods described herein where the life safety of workers and public are affected. Any departure from the original design of the equipment used in this manual that may impact the intended use of the equipment and associated building systems should be limited solely to enhancing life safety and not for any reason that could compromise safety.

This manual, which is the result of extended and careful consideration of available knowledge and experience on the subject, is intended to provide minimum requirements that are recommended for use by persons in the suspended maintenance trade or who provide equipment or supplies to the trade, persons who employ or contract their services, and for designers and engineers that specify these systems.

It is recognized that, although the suspended maintenance methods, procedures and materials included herein are widely used and accepted, new developments are to be expected and revisions of the standards are necessary as the industry progresses and further experience is gained.

This document is copyrighted by Engineered Supply LLC (ES). All rights are reserved.

Reproduction of in any format be it verbal, written, electronic or computerized is strictly prohibited without the expressed written consent of ES.

DEDICATION

This equipment manual is dedicated to those who have been injured or killed during falls from height.

Hold paramount the safety, health, and welfare of the public.

GENERAL

a. Safety Precautions

Safety and health concerns are beyond the scope of this standard and therefore are not fully addressed herein. It is the responsibility of the user to establish appropriate safety and health practices. Material or Equipment Manufacturer's Safety Data Sheets and Operating Manuals as well as Applicable Regulatory Agencies shall be considered when developing a safety program.

b. Limitations

This standard was specifically developed for suspended maintenance applications using Engineered Supply's anchorage connector products. Some of it may be applicable to other systems such as fall protection, but it is not the primary intent of this manual. This manual does not address all situations that will be encountered.

c. Responsibilities

The certifying Professional Engineer shall be responsible for the development of the log book, including documents that govern products and structural assemblies produced under this code. The Professional Engineer may add to, delete from, or otherwise modify, the requirements of this code to meet the particular requirements of a specific system provided the modifications are recorded in the log book. The Professional Engineer shall determine the suitability of all anchorage connectors and system layouts to be used in a suspended maintenance system.

The Professional Engineer shall consult with the building owner and, when known, the system user and incorporate their preferences within the confines of the applicable standards and past experiences with system designs.



**ENGINEERED
SUPPLY®**

EQUIPMENT MANUAL

SUSPENDED MAINTENANCE ANCHORAGE CONNECTORS

SECTION ONE

System Design

Engineered Supply provides system designs.
This section includes information on standard systems
and how they are used in the industry.

SYSTEM SELECTION

Notes and Key Notes for Figure S-A

- 01 Ground, supported scaffold, and ladder access is typically used up to 3 stories / 30 feet. Ladder access is limited to work that can be done with one hand, such as window washing. Standard scaffolds can be erected to much greater heights, but are typically not cost effective unless rope access, lifts, stages, and cranes are not reasonable.
- 02 Mid rise and high rise window washers use rope descent to access windows higher than 30' above grade up to 300' above grade, where anchorage connectors are available. Some Authorities Having Jurisdiction place additional restraints (such as in the State of California) or restrict rope descent (such as in the State of New York). Rope descent is a specialized method of access and, while cost effective, only specialty contractors know how to use this equipment. Most if not all high rise window washers have experience with rope descent where it is allowed by the local authority having jurisdiction.
- 03 Lifts are used where there is obstruction from ropes and cables above, or there is not a place to launch from (such as a sloped roof) and there is an area to operate the lift without closing streets. Lifts are cost effective in comparison to swing stages up to approximately 6 stories / 60 feet. Larger lifts can easily cause damage to landscaping, curbing, and the building. Lifts are easier to operate than swingstages at low rise buildings where there is ground area to operate them without closing public streets. Skilled operators for lifts are common in most construction and maintenance trades. Openings for rope access or other features such as fly decks may be utilized for locations where lifts are not reasonable.
- 04 Swingstages (supported scaffolds) are used for access when work being completed requires two hands, the drop height is over 300' for window washing, or when conditions do not allow for descent and moving upwards is required (rope descent does not allow for traveling upwards on the rope efficiently). Swingstages are roof launched on buildings over 300' tall. Most swingstages are transportable, and owned or rented by the company doing the work. Buildings over 500' tall commonly have dedicated swingstages typically called building maintenance units (BMUs) or house rigs.
- 05 Cranes equipped with suspended man baskets are inconvenient for both the user and the adjacent use in comparison to rope descent, lifts, and swing stage. They are not cost efficient over the life of the building, and can easily cause damage to landscaping and sidewalks. They are used for suspended maintenance where no other option exists (area to be accessed is too high or there is too much horizontal reach for a lift and anchorage connectors are not available). They are used for specialty work where there is not access to run cables from a roof such as on agricultural silos and grain legs where a lift will not reach.
- 06 Rope descent may be used for washing windows lower than 30' above grade, for instance when the grade cannot support ladders or when the remainder of the building is accessed with ropes and the setup of ladders or lifts is not warranted.
- 07 Rope descent may be used on existing buildings higher than 300' above grade, if swingstages are not practicable and the local authority allows (for instance in situations where a swing stage cannot be launched from the roof practicably). The competent qualified person performing the work shall determine that roping above 300' is reasonable in all cases. Note that rope descent may have additional limitations, such as in the states of California and New York.

FIGURE S-A

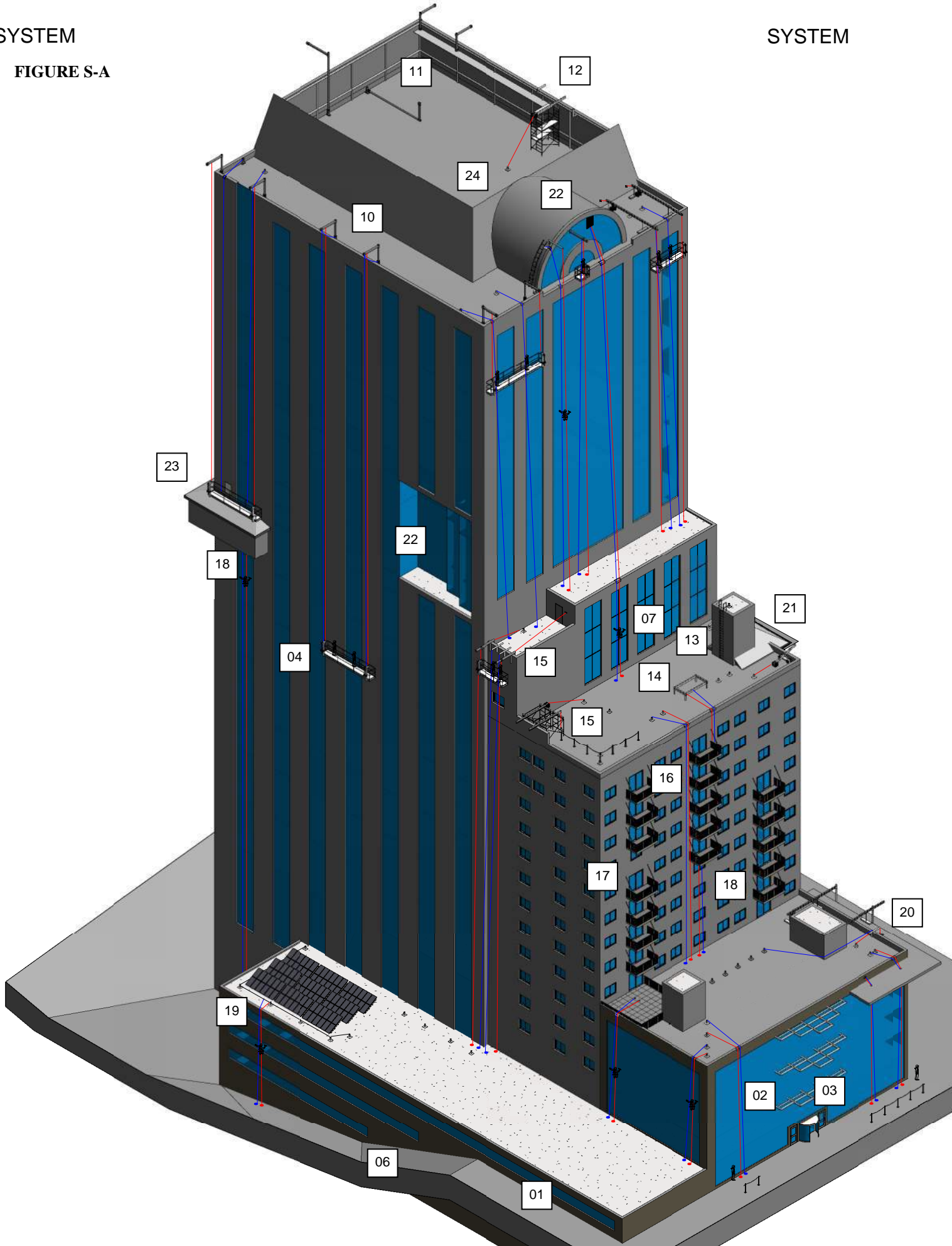

Notes and Key Notes for Figure S-A

08 Counterweight beams locate the drop cable for hoists 1' to 2' out from the face of a parapet wall (the distance is dependent on the stage configuration) to keep the swingstage from running into the face of the building and keep the weight of the loaded line off the parapet wall. They use a stack of weights on the end of a beam to provide a factor of safety of four. Commonly if you use a 1,250 pound hoist, with a 2' cantilever, then 1,250 pounds of counterweight is placed on a backspan that is 8' long (10' long beam). Less counterweight can be used with longer backspan or shorter outreaches. More counterweight can be used with shorter backspans or longer outreaches provided the ratio stays at a factor of safety of four. Counterweight beams are required to be tied back to an anchorage connector to prevent the beam assembly from sliding forward, and to provide a safety if there is a detachment of the weights or an overload.

08 Fall protection lines (shown in blue by this manual) are considered to load the anchorage connector, but the ultimate load is not applied to members that support the lines. The fall protection line is protected against abrasion and breaking in the event of an accident by rope protectors or by qualified abrasion testing of the cable assembly. These lines do have a maximum service load of typically less than a few hundred pounds (the weight of the rope and a small amount of pull in the case that someone tugs on it). Because of this service load, they are not commonly supported by sensitive items such as glass guard railings.

09 Rope descent lines and similar loaded lines (shown in red by this manual) place load on the supporting members that they intersect, such as parapet walls, and then load the anchorage connector at the end of the rope. In rope descent it is a common approach by competent qualified persons to treat existing members supporting loaded lines as being service loaded with less than a thousand pounds line tension and not the full 5,000 pounds breaking load (the competent qualified persons are accepting damage to the supporting elements in the case of an ultimate / accident load). Engineered Supply recommends using outrigger beams on all loaded lines, but acknowledges the industry does not always take this approach.

10 Davit arms are used to roof launch the stage (roof launching is picking up the stage above a flat roof, and then the davit arm turns out to allow the stage to move down the face of the building). Roof launching is used at buildings with drop heights over 300'. The primary reason for roof launching is that to ground launch over 300' the cables are more prone to blowing away from the building. Secondly, to use intermittent stabilization anchors (ISAs) with a ground launched swingstage, the stage must travel from the ground elevation to the top (or above the work area) with no tie into the building, and it is difficult to maintain constant contact with angulated rigging at this height (the stage may blow away from the face of the building during the initial ascent if ground launching).

Existing davit arms are sometimes rated for one 5,000 pound breaking load, but in practice support both the primary and secondary lines. Engineered Supply requires that the secondary line be secured to a properly rated independent anchorage connector, the secondary line may be routed through the davit arm to keep load off of items such as a glass guardrail or if the hoist is dual reeving.

- 11 It is best practice to include a catwalk if the parapet wall is equal to or greater than 10' tall. These catwalks are not required by the standards, but will pay for themselves over time due to the amount of time it takes to set up scaffolding to get over the wall. Note that ladder work shall be limited to work that requires only one hand in order to maintain three points of contact, and that it takes more than one hand to rig suspended maintenance lines.
- Standard davit arms can reach up to 8'-6" and have up to a 12' height to allow for the stage to clear the parapet walls and any ancillary items such as lightning protection. Davit arms may be taller and longer to reach over tall parapet walls, however if they exceed a portable weight or portable reach they shall be left stationary at the base and not moved around to other bases.
- 12 Rigging arms for ground launch are commonly called counterweight beams, pinned beams, or rigging sleeves if the rope passes through them. On taller ground rigged drops it is advantageous to terminate the rope away from the drop edge, as the weight of the rigging is more difficult to control with the termination over the side of the building.
- 13 Fixed ladders should be included when access to anchors require more than a 16' vertical climb.
- 14 Natural anchors are acceptable provided the base material can receive the intended loading, and the transportable rigging considered for the attachment is identified by note in the user manuals. During system upgrades it is best practice to include a standard anchorage connector.
- 15 Counterweight beams are required to be tied back to an anchorage connector in an accident event such as if the weights become dislodged, or the beam tips over.
- Pinned outrigger beams do not require transportable weights and are directly attached to the structure.
- 16 Window washers may be responsible for cleaning exterior balcony doors, however they may not have access through some residential units. In these cases, it is common for drops to be included for accessing patios.
- 17 Windows above balconies may be serviced by a portable ladder if there is adequate room to foot and access the ladder.
- 18 Balconies regularly do not exist over lower levels that sometimes results in windows too high to service with reasonable ground based equipment (typically glass over 30' high is serviced from a rope). In these cases rigging sleeves through the lowest patio or other similar under rigging is commonly incorporated. Mid air transfers to other anchorage connectors are not recommended. For existing systems that include provisions for mid air transfers, it is better practice to rig from the underslung anchors and then use a power ascender to go up the rope.
- 19 Areas with access less than 6' wide typically are equipped with a horizontal life line to allow for transversing. This horizontal life line may be used for a secondary tie off provided its ends are secured to anchorage connectors separate from the ones being utilized for the loaded line and the shock absorber can support the planned horizontal service line load without deploying.



- 20 Overhangs more than a few feet wide have a number of approaches for suspended maintenance rigging setups including:
- Vertical Rigging Sleeves. These are fixed penetrations leading to the soffit that allow a line to be attached.
 - Down and under beams. These transportable beams require a flat roof to set them up and then the beam extends out past the roof edge, down below the overhang and then back under the soffit to the drop location.
 - Rigging Holes. These are a pass through that allow for a cable to be dropped through the soffit. If the stand or beam above supporting the rigging line is not directly attached, then it shall be tied back to an anchorage connector. If the stand pins in place typically tie back lines are not utilized.
- 21 High rise roofs with slopes equal or steeper than 4 on 12 typically have a flat portion by the perimeter parapet wall to allow for standard suspended maintenance. Low rise buildings requiring suspended maintenance typically have rigging sleeves out the soffits with access in the attic spaces.
- 22 Obstructions and features at high roofs can have access devices such as ladders, doors, rigging sleeves, and rope guides.
- 23 Low roofs should have access doors. Preferably doors are made to slide and not swing, as the swing doors are easily caught in the wind.
- 24 Post one hard copy of a log book inside near the main, accessible roof access.
- a. At each non main roof access, post a log book location sign directing the system user to the location of the main, accessible roof access.
 - b. Each anchorage connector shall be given an identifying number that correlates to a line in the log book. This mark shall be made durable enough to last between certification periods.
 - c. The log book shall include places to record: maintenance, testing, retesting, system usage, and annual inspections.
 - d. The log book shall include a certified system layout drawing indicating the vision glass requiring washing, anchorage numbers, floor to access the roof, roof elevations for each level with anchorage connectors, lowest grade elevation, a true north arrow, drop locations, method of access (rope, swingstage, or other), typical rigging to be used, and any specific portable equipment that is required. Drawing certification shall cover the anchorage layout, method of use, strength of the anchorage connectors, and strength of the secondary and primary supporting structure.

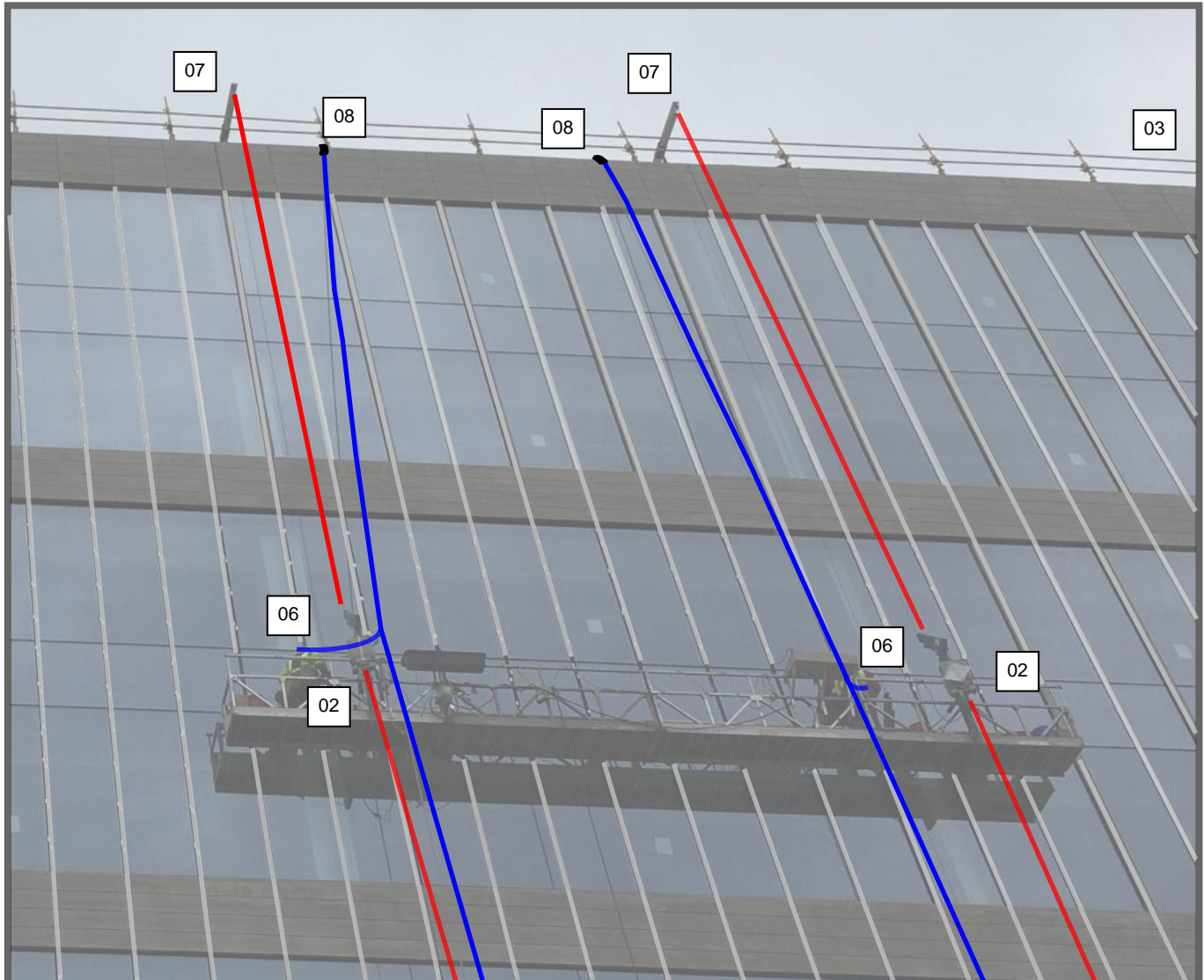

- 01 Swing Stage, Ground Rigged
- 02 Hoist
- 03 Edge Fall Protection, Temporary
- 04 Primary Line
- 05 Secondary Line
- 06 User with Harness, Shock Absorbing Lanyard, and Rope Grab attached to Secondary Line
- 07 Counterweight Beam, Cantilevered
- 08 Edge Protection

Ground Rigged Swing Stage Secondary Lines shall extend to safe landing surface below.

Edge Protection shall be provided at all line contact locations.

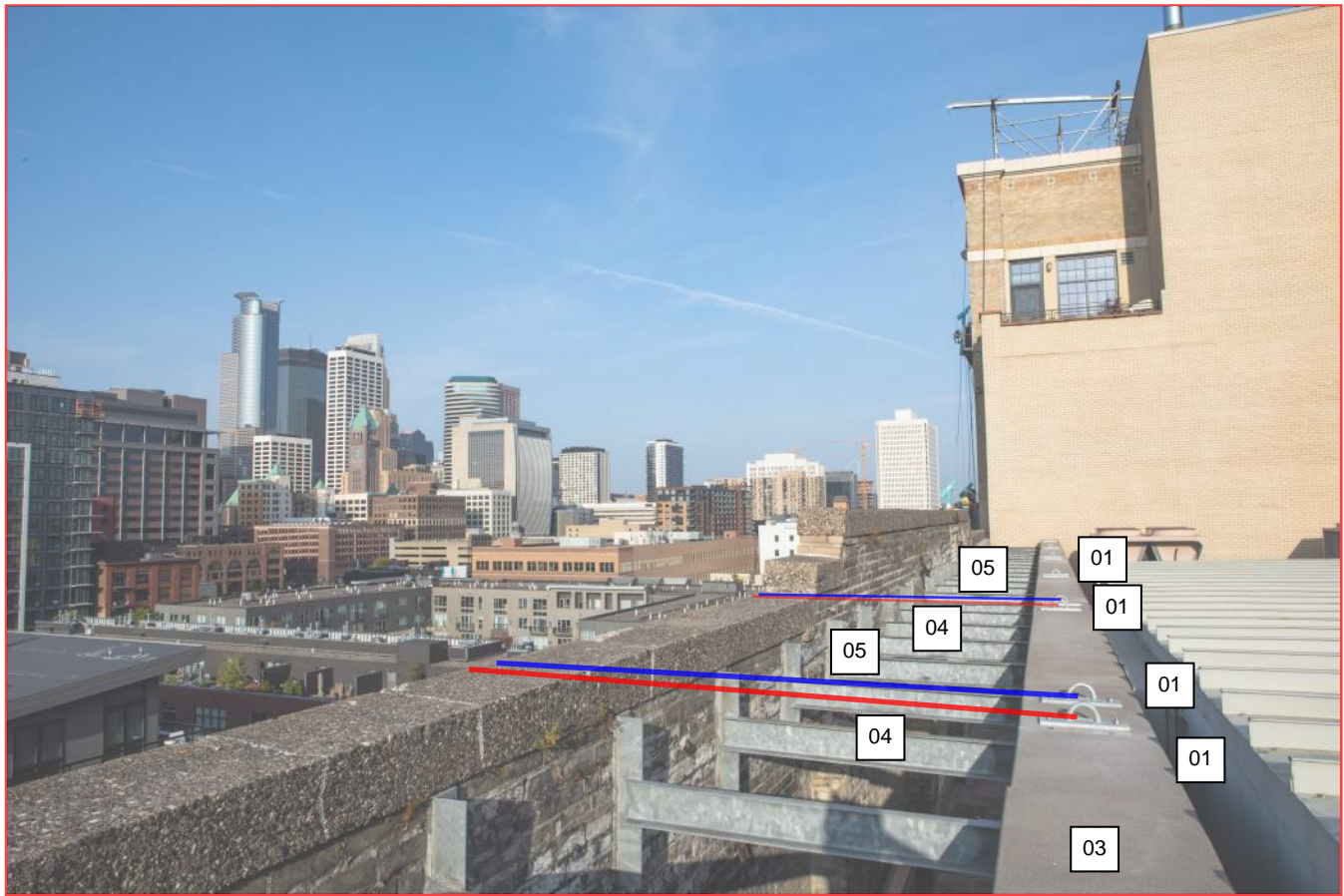

- 01 Anchorage Connector
- 02 Anchorage Connector Hardware
- 03 Structure
- 04 Primary Line
- 05 Secondary Line
- 06 Descender
- 07 Rope Grab
- 08 Boatswain Chair

Window washers work in pairs of two. Each window washer uses two lines. Loads to the anchorage connector are calculated based on number of attached lines. Unless otherwise determined by the project's Professional Engineer, the primary structure shall be designed for any two lines loaded simultaneously. If an existing Primary Structure's main lateral system cannot support two simultaneous loads and is not strengthened, the Log Book shall state the limitation on number of Users and provide suggestions for plausible and timely rescue scenarios.

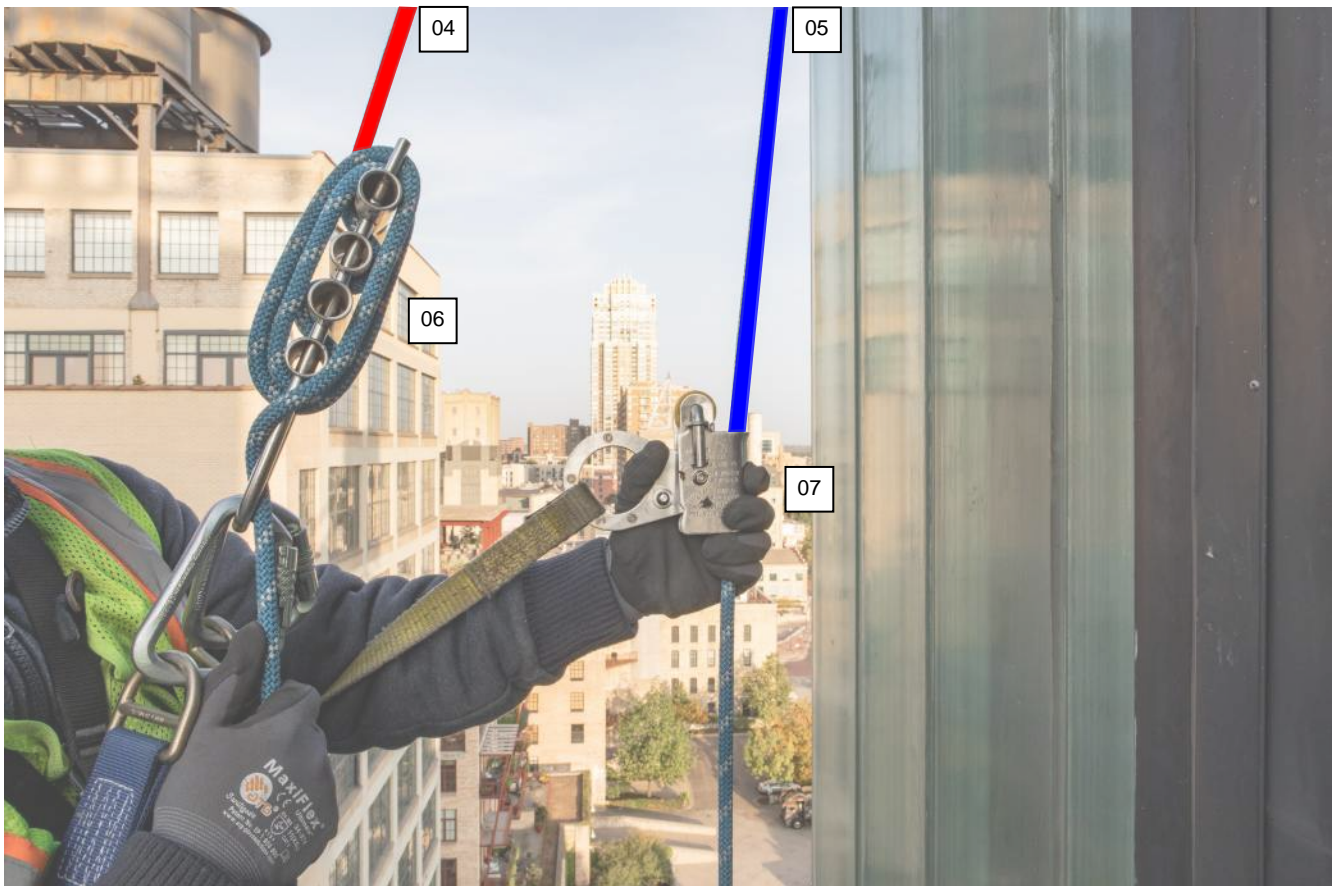



**ENGINEERED
SUPPLY®**

EQUIPMENT MANUAL

SUSPENDED MAINTENANCE ANCHORAGE CONNECTORS

SECTION TWO

Anchorage Connectors

Engineered Supply has provided tens of thousands of suspended maintenance anchorage connectors on thousands of projects. This section includes information on our standard anchorage connectors and also provides examples of common custom equipment and miscellaneous metals.

The most important part of the anchorage connector is the hoop, or connection point eye: the piece that the rope is tied to, the carabiner snaps to, a clevis is affixed to that directly receives the load from the primary or secondary line.

Manufactured hoops are commonly engineered for compatibility, ductility, stiffness, and impact resistance which is critical at low temperatures.

Better hoop design for compatibility maintains a standard 3/4" diameter round section while reducing side gate loading by maintaining a large radius. ANSI Z359.18-T requires a 1" diameter eye minimum. The State of California requires a 2" minimum eye diameter. The drawback of a larger diameter is the serviceability of the anchorage connector is not acceptable if the hoop cannot be field tested or even worse, if the hoop bends under service loading. Deformation during impact loading is acceptable, except unless required otherwise, such as the State of California's requirement that the anchorage connectors for suspended maintenance do not deform at 5,000 lbf applied at the hoop for suspended maintenance anchorage connector.

A large number of attachment gates are designed to allow a maximum of 3/4" diameter round body to latch in. Hoop bodies that are significantly larger than 3/4" may require an intermediate clevis to allow for attachment and should not be allowed for new manufactured anchorage connectors. Hoop bodies smaller than 5/16" in diameter shall not be used.

Engineered Supply standard patented StrongTop hoops are a 3/4" diameter A529 Grade 55 hot rolled solid round that is work hardened by cold forming to a 1.625" inside diameter with a 2" clear distance from the top of the plate to the bottom of the inside radius and having a Charpy V Notch impact test and inserted through a hole in the attachment plate with weld on both the top and bottom of the hole. This patented hoop design is elastic with 5,000 lbf applied at the top, permanent deformation onsets between 7,000 and 8,000 lbf applied perpendicular to the hoop, remains ductile without cracking to over 20,000 pounds static force applied to the top of the hoop in any direction, has been tested to and certified meeting the ANSI Z359.18 cold temperature requirements, has been successfully qualification tested on over 50 ANSI Z359.18-T anchorage connectors, and is sized by calculation to support the IBC required 3,100 lbf line load using the current version of the AISC Manual.





The easiest to fabricate hoops are made from 3/4" diameter austenitic stainless steels, commonly 304 and 316 grades. The relatively high ductility of stainless steels allows them to be cold formed to a relatively tight radius without cracking. The relatively low yield strength allows them to absorb energy during an impact through permanent deformation. The main drawback of a stainless steel hoop is that to remain economical it is commonly welded to a dissimilar mild steel plate. This weld crosses over from AWS D1.6 to AWS D1.1, and shall have the input of a licensed professional engineer in metallurgy to certify the procedure and weld as acceptable. This welding of stainless to mild steels also causes a galvanic difference which may lead to corrosion, and this is to be understood by the project's Professional Engineer. Austenitic stainless steels do have an advantage over exposed painted finishes as they are not as prone to corrosion where connectors may cause wear. They also have an advantage in low temperatures as they commonly do not have the same cold temperature embrittlement issues when compared to typical mild structural steels exposed to impact loadings.

The most difficult to fabricate hoops are the cast or forged steel type. These require selecting the base metal and making a custom run which may have a long lead time. The advantage to a cast hoop is being able to select a cross section that both allows a standard gate to latch on where the stresses are low, but also can increase in dimension where the stresses are higher. Cast hoops can commonly be designed to remain elastic under a 5,000 pound qualification load test. The issue with cast or forged hoops is a loss of transparency, as the metals are not widely used by structural engineers in the building industry so weld-ability, ductility, yield stress, ultimate stress, and cold temperature impact resistance will not be known unless the manufacturer publishes the data (which is uncommon). A Professional Engineer shall not certify a new anchorage connector with a cast hoop without industry standard knowledge to rely upon. ANSI Z359.18-T certification is an acceptable qualification test, as well as having a professional engineer from the manufacturer certify that the hoop performs to the project requirements.

ANCHORS

The simplest form of manufactured anchorage connector is a welded plate anchor, which is a hoop or eye affixed to a base plate of steel. This style has flexibility as a secondary structure can be used between the anchorage connector and the primary structure to suit most custom situations.

It is also normally the lowest cost anchorage connector in new construction on screen wall frames and mechanical support units as most of the supporting structure would exist without the anchorage connector there.

These may be shipped with a plain finish, and hot dipped or otherwise coated with the primary structure if necessary.

All welders and weld procedures shall be qualified per the applicable AWS specifications.

ANCHORS

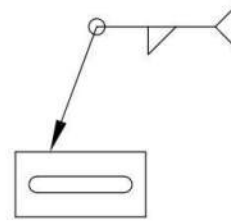
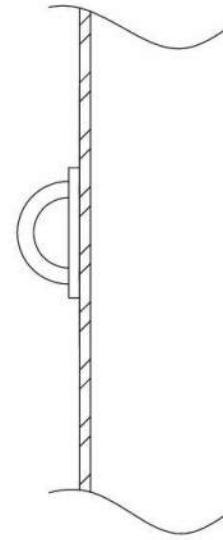



Engineered Supply stocks all our plate anchors for delivery to all 50 states.

ES Weld On Plate Anchors
(stocked in plain and hot dip finish)

Note: hot dip finish required for ANSI Z359.18-T compliance



The next most economical anchorage connector is a bolted plate anchor, which is a hoop or eye affixed to a base plate of steel with holes for bolts.

Through bolts are the most common hardware, however these anchorage connectors may be attached to concrete with expansion bolts rated for seismic loading (so they do not loosen over time). They are also attached with adhesive anchoring systems or cast in bolts into masonry and concrete. The manufacturer of the hardware system shall have an ICC or equivalent report, and recommend their product for use in fall arrest and suspended maintenance systems. Suppliers such as Hilti are commonly acceptable, some suppliers such as Simpson Strongtie do not recommend their products for use in fall protection systems and therefore should not be used.

All nuts are required to be vibration resistant through the use of double nutting with a torque applied to the inside and outside nut, thread deformation, single nut with torque having a calculated clamping force exceeding the yield strength of the net threaded tensile section, or chemical thread lockers. Lock washers are not an acceptable form of vibration resistance. Turn of the nut is not an acceptable form of torque for anchorage connectors.

304 and 316 stainless anchorage connector hardware is typically used, as the galvanic difference protects the smaller threaded part. While hot dip hardware is sometimes judged acceptable, the ductility of stainless and its cold temperature performance through the threaded section makes it a common choice. In no case shall an electroplate or other fastener be used in a concealed or exterior use for the connection of the anchorage connector to the secondary structure. Standard finish is acceptable for the primary structure provided the roofing / building envelope vapor barrier can serve as a line between the corrosion resistant and typical primary structure.

A minimum of two bolts shall be used to prevent the anchorage connector from spinning during verification load testing (anchorage connectors with a single bolt should be avoided for suspended maintenance applications).



ES Stainless Standard Plate Anchors (stocked in 304 and 316)



ES Standard Plate Anchor



ES Wide Plate Anchor (for wood and masonry)

Engineered Supply stocks all our plate anchors with common hardware for delivery to all 50 states.

ANCHORS

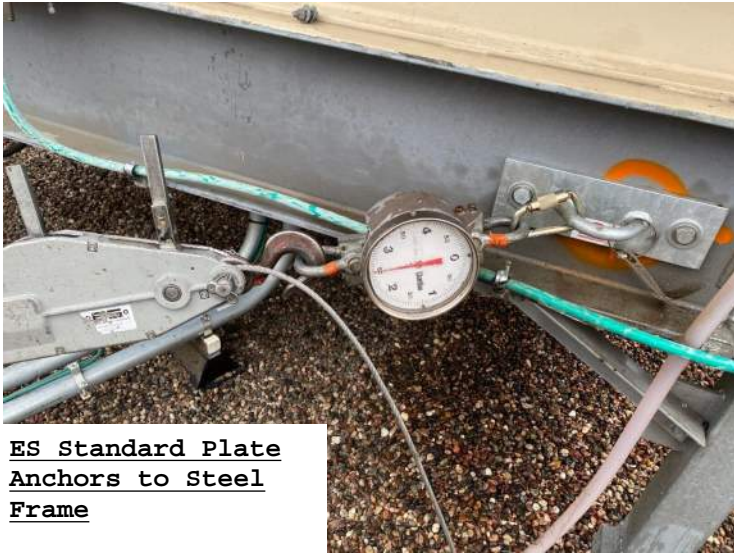

ES Standard Plate Anchors to Steel Frame

ANCHORS



ES Standard Plate Anchors to Cast In Place Penthouse Wall



ES Wide Plate Anchor to Solid Reinforced Masonry wall At Corner



ES Stainless Standard Plate Anchors to Cast In Place Penthouse Wall



ES Standard Plate Anchors to Solid Precast Parapet Wall

Engineered Supply stocks all our plate anchors with common hardware for delivery to all 50 states.

A common anchorage connector is a welded pipe anchor, which is a hoop or eye affixed to a top plate over a pipe. This arrangement allows for a varying height of pipe to attach from the primary structure and pass through the roof decking, roof insulation, and have a standard roofing boot provide the building envelope seal.

Mild steel A500 is a common structural pipe to use, as the A53 grade typically comes with a protective finish that is not suitable for hot dip galvanizing without prior sandblasting.

All hot dip galvanizing shall be removed from the heat affected zone prior to welding. Welding secondary structure through metal roof decking is prohibited (roof deck shall be removed at the weld locations to allow for an AWS prequalified weld from structural steel to structural steel with no light gage metal between the members being joined).

If being welded to the top of a narrow wide flange beam, or double chord of a joist, the pipe shall have an interface plate welded on so the pipe may be welded all around. Partial welds from a pipe with a larger outside diameter than the width of the wide flange or bar joist material should not be allowed.

A common legacy anchorage connector detail for attachment to wide flange beams omits the stiffeners and bottom flange bracing required to provide use in all possible directions. In the case of an existing legacy pipe anchor connection being on an unstiffened wide flange with no calculated strength perpendicular to the wide flange span but adequate strength parallel to the wide flange span the anchorage connector shall be labeled as a directional anchor in the field and in the log book, or red tagged out of service until it can be repaired.

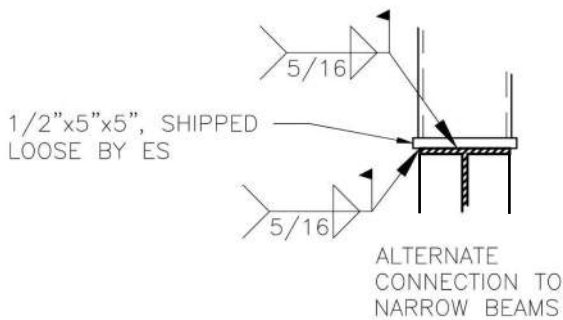

Engineered Supply stocks weld on pipe anchors for delivery to all 50 states.



Engineered Supply StrongTop Anchor to Bar Joist

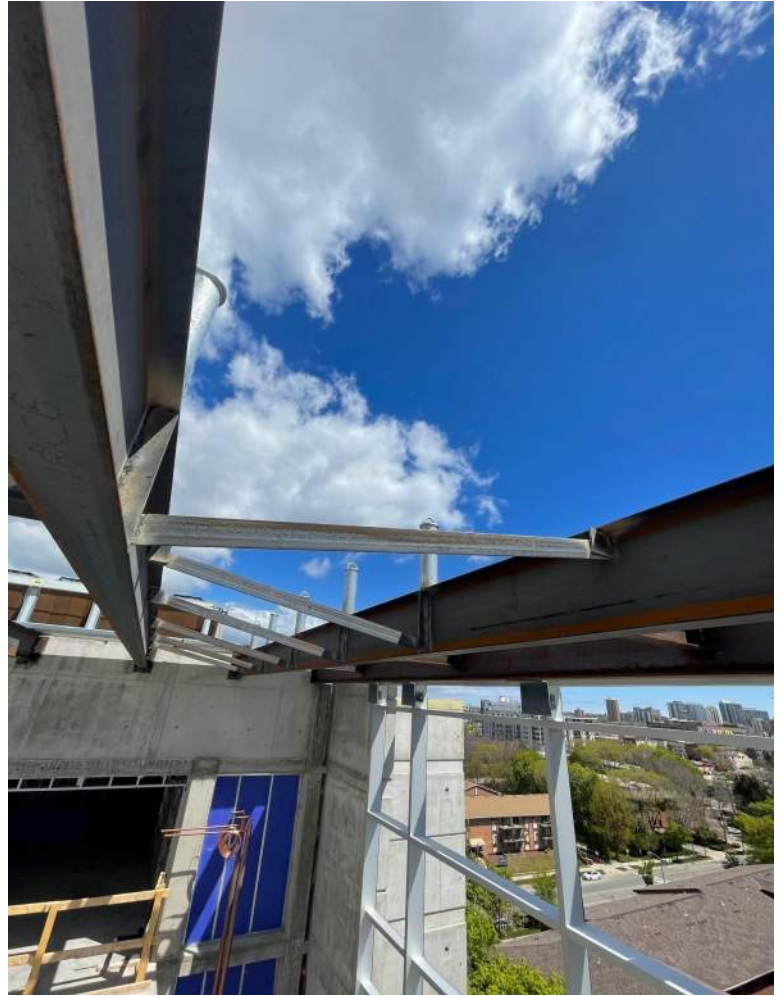

Engineered Supply StrongTop Anchor to Reinforced Wide Flange Beam



Engineered Supply StrongTop Anchor to Tube Spreader



Engineered Supply StrongTop Anchor to Heavy Structural Steel Truss



Engineered Supply StrongTop Anchor to Composite Steel Beam





Engineered Supply stocks our StrongTop anchors and most hardware for delivery to all 50 states.

Another typical Anchorage Connector is a pipe anchor with a base plate. Common pipe outside diameters range from 3" to 4.5" for heights between 10" and 30". Base plate outside dimensions range from 5"x5" square to 24"x24" square. Hole patterns are typically proprietary. Engineered Supply uses a 15.5" square base plate with 12 holes as a universal pattern, and stocks a 23.5" square with a 14" tall pipe for older structures with thinner concrete thicknesses. Wider base plates often use thinner sections, usually 1/2" is a minimum thickness for a short pipe height. Taller pipes require thicker base plates, it is uncommon to have thicker than a 3/4" 50 ksi yield base plate on a pipe anchorage connector.

Base plates with more than two rows of bolts around the four perimeter sides should not be used for suspended maintenance. If more than two rows are used, past experience has shown that during verification test loading the anchorage connector hardware may be subjected to varying loads causing loosening of some fasteners which is cause for red tagging the anchorage connector out of service.

A minimum of three bolts shall be used to prevent the anchorage connector from rocking and loosening during verification testing.

A36 steel shall not be used in anchorage connectors without review of the material certs by the Professional Engineer. It is acceptable for the primary and secondary structural supports.

Stiffeners may be used on base plates, however it is not typically economical and the local stresses shall be considered for fatigue and tested for cold temperature impact performance where applicable.

Engineered Supply stocks a nominally 24" square baseplate anchorage connector with a 14" tall pipe for post installing to thinner concrete structures.



This document is the sole property of Engineered Supply



ANCHORS



ES StrongTop Anchorage Connector Post Installed on Concrete

ANCHORS



ES StrongTop Anchorage Connector Cast in Concrete



ES StrongTop Anchorage Connector on Wood Plinth

Engineered Supply stocks our universal anchors with most types of hardware for fast delivery to all 50 states (including stocking the wood plinths).

Patio Anchors

Occupied rooftop areas regularly have pavers set on pedestals.

It is acceptable to locate a standard anchorage connector below a removable paver provided the paver is permanently marked, and the log book indicates more than the approximate location (for example the anchorage connector shown in Photograph X-x shall be located in the log book by stating 3 pavers in from the south and 3 pavers in from the west side on the main roof patio). It shall also be communicated in the log book that removing and replacing pavers may cause damage to the pavers, and may lead to loose and uneven pavers after removing and replacing them repetitively over the life of the building.

It is preferable to use an anchor with a flip up hoop as shown, or an anchor with a removable cover.

The log Book usage plan should be coordinated with patio furnishings.

In no case should pots weighing more than 80 pounds be located over anchorage connectors. In no case should permanent fixtures such as irrigation plumbing be required to be unhooked to access the anchorage connectors for window washing. In no case should dog runs be allowed to cover over anchorage connectors located below the pavers.



Engineered Supply stocks flush patio anchors and below paver anchors for delivery to all 50 states.



This document is the sole property of Engineered Supply



ES PATIO ANCHOR



ES PATIO ANCHOR



ES BELOW PAVER ANCHORAGE CONNECTOR

ES CAST IN FLUSH WALL ANCHOR (WITH COVER)



ANCHORS



ANCHORS

Vertical rigging sleeves are a permanent method of going through overhangs. They are a preferred option over down and under transportable equipment as they do not require counterweights to be brought to the roof.

Rigging sleeves are required to be used where access is limited, and counterweight beams would be unsafe during setup.

Where the top side of rigging sleeves are exposed to exterior conditions, they should be provided with a cap to reduce water stains and reduce icicles on the soffit below.

ES VERTICAL RIGGING SLEEVES WITH ES BYPASS HORIZONTAL LIFELINE



ES FLUSH RIGGING SLEEVE

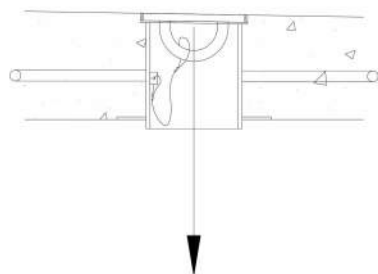

ES VERTICAL RIGGING SLEEVE

ANCHORS

Engineered Supply custom engineers and in house manufactures our rigging sleeves, stocking the typical components to them. We are available to turnkey supply these fixtures in all 50 states.



ES VERTICAL RIGGING SLEEVE



ES RIGGING SLEEVE



ANCHORS

Horizontal rigging sleeves are commonly used where standard transportable equipment would not fit.

Care needs to be taken to properly communicate how much line angularity is designed for when fixed sleeves are utilized.



ANCHORS



ES HORIZONTAL
RIGGING SLEEVE

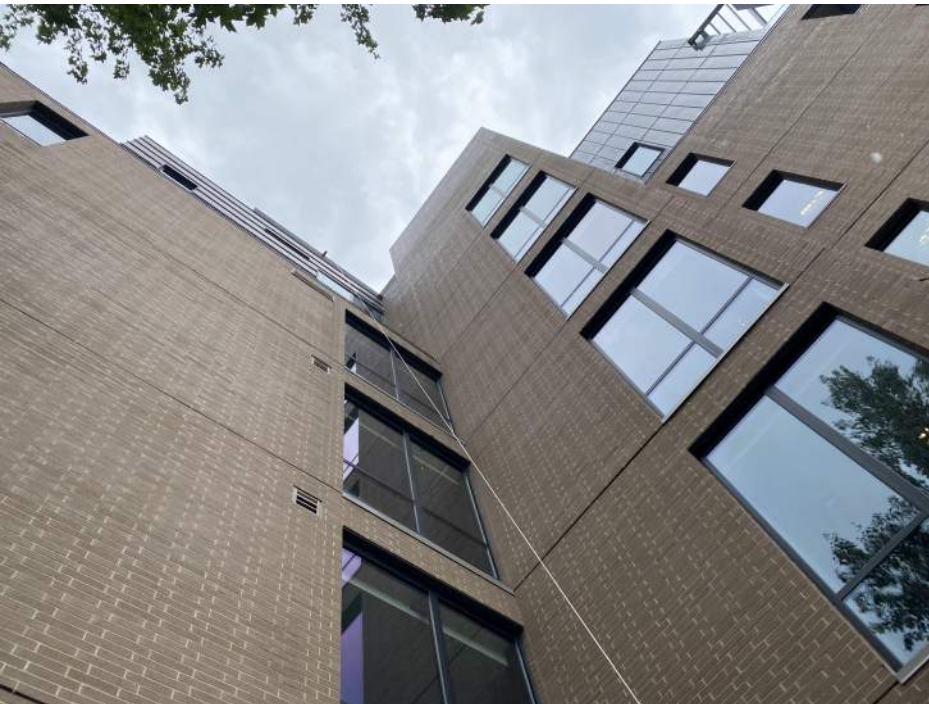

Engineered Supply custom engineers and in house manufactures our horizontal rigging sleeves, stocking the typical components to them. We are available to turnkey supply these fixtures in all 50 states.





Engineered Supply custom engineers and in house manufactures our rigging arms, stocking the typical components to them. We are available to turnkey supply these fixtures in all 50 states.

ES RIGGING ARM

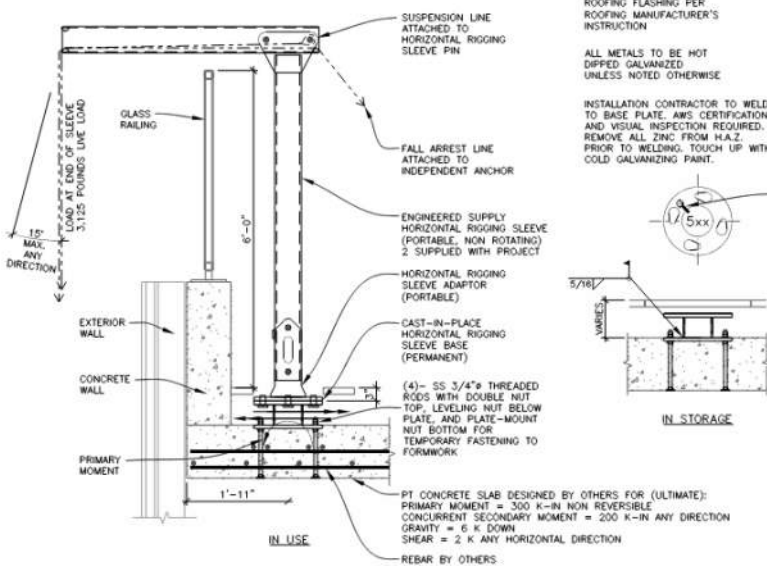

ROOFING FLASHING PER ROOFING MANUFACTURER'S INSTRUCTION

ALL METALS TO BE HOT DIPPED GALVANIZED UNLESS NOTED OTHERWISE

INSTALLATION CONTRACTOR TO WELD TO BASE PLATE. AWS CERTIFICATION AND VISUAL INSPECTION REQUIRED. REMOVE ALL ZINC FROM H.A.Z. PRIOR TO WELDING. TOUCH UP WITH COLD GALVANIZING PAINT.

THIS SYMBOL INDICATES THE ORIENTATION OF THE RIGGING SLEEVE BASE PLATE. THE SMALL HOLE IN THE BASE PLATE SHALL MATCH THE ORIENTATION OF THE SYMBOL SHOWN ON PLAN.

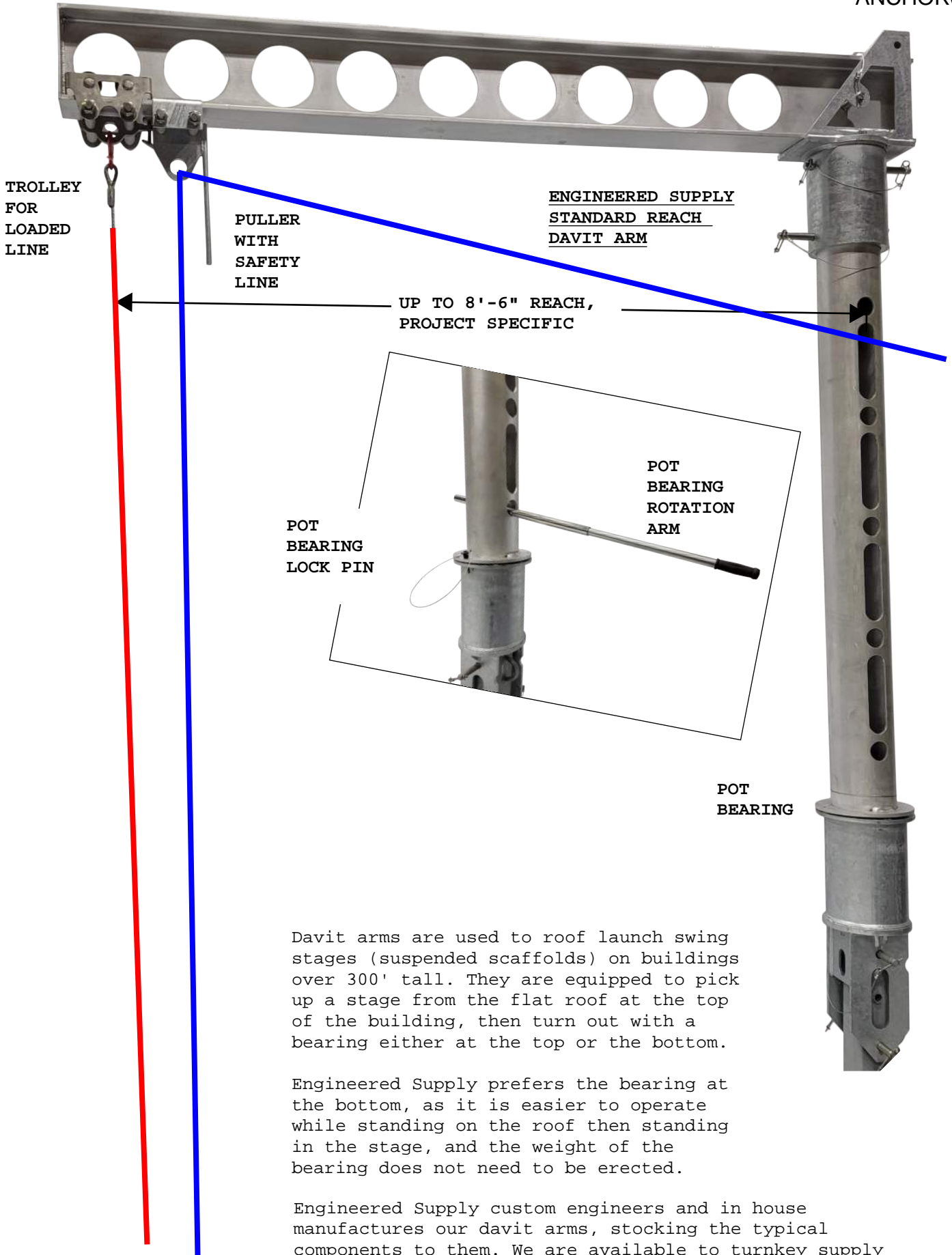

Davit arms are used to roof launch swing stages (suspended scaffolds) on buildings over 300' tall. They are equipped to pick up a stage from the flat roof at the top of the building, then turn out with a bearing either at the top or the bottom.

Engineered Supply prefers the bearing at the bottom, as it is easier to operate while standing on the roof than standing in the stage, and the weight of the bearing does not need to be erected.

Engineered Supply custom engineers and in house manufactures our davit arms, stocking the typical components to them. We are available to turnkey supply these fixtures in all 50 states.



ENGINEERED SUPPLY
LONG REACH
DAVIT ARM BEING
ERECTED

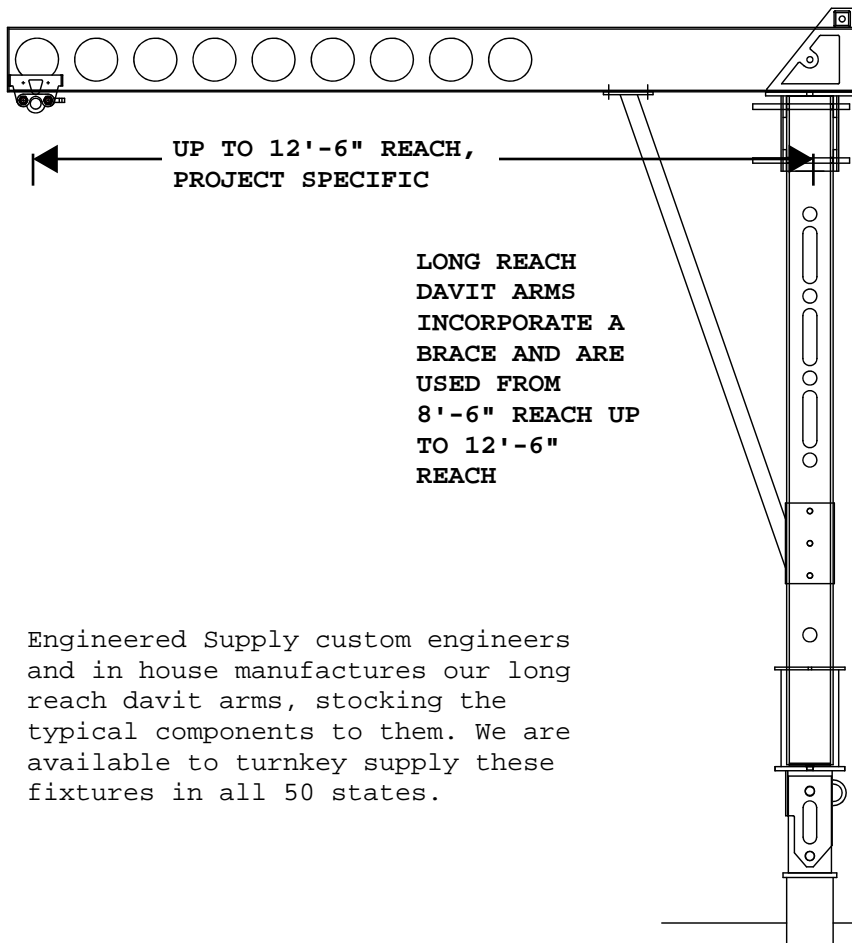
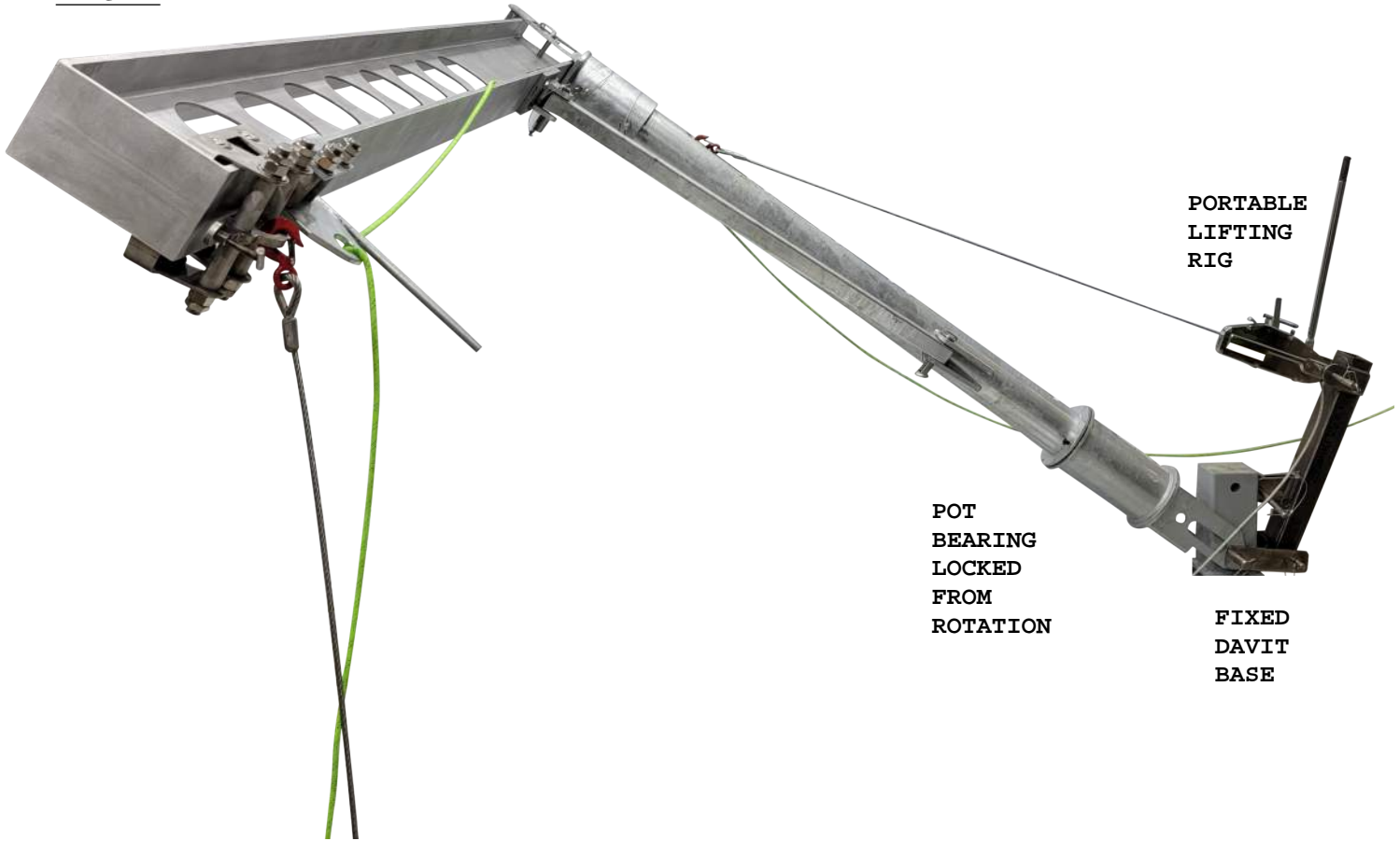

Davits are jib cranes used for roof launching swing stages on buildings over 300' tall, where rope descent is typically not allowed by standards.

The basic process is to have a number of davit bases fixed to the structure, then have a mobile adapter that moves from base to base.

The mobile adapter receives an arm assembly, and a lifting kit is used to erect the arm from the horizontal position into the vertical position.

Engineered Supply custom engineers and in house manufactures our long reach davit arms, stocking the typical components to them. We are available to turnkey supply these fixtures in all 50 states.

Engineered Supply custom engineers and in house manufactures our extra long reach davit arms. We are available to turnkey supply these fixtures in all 50 states.

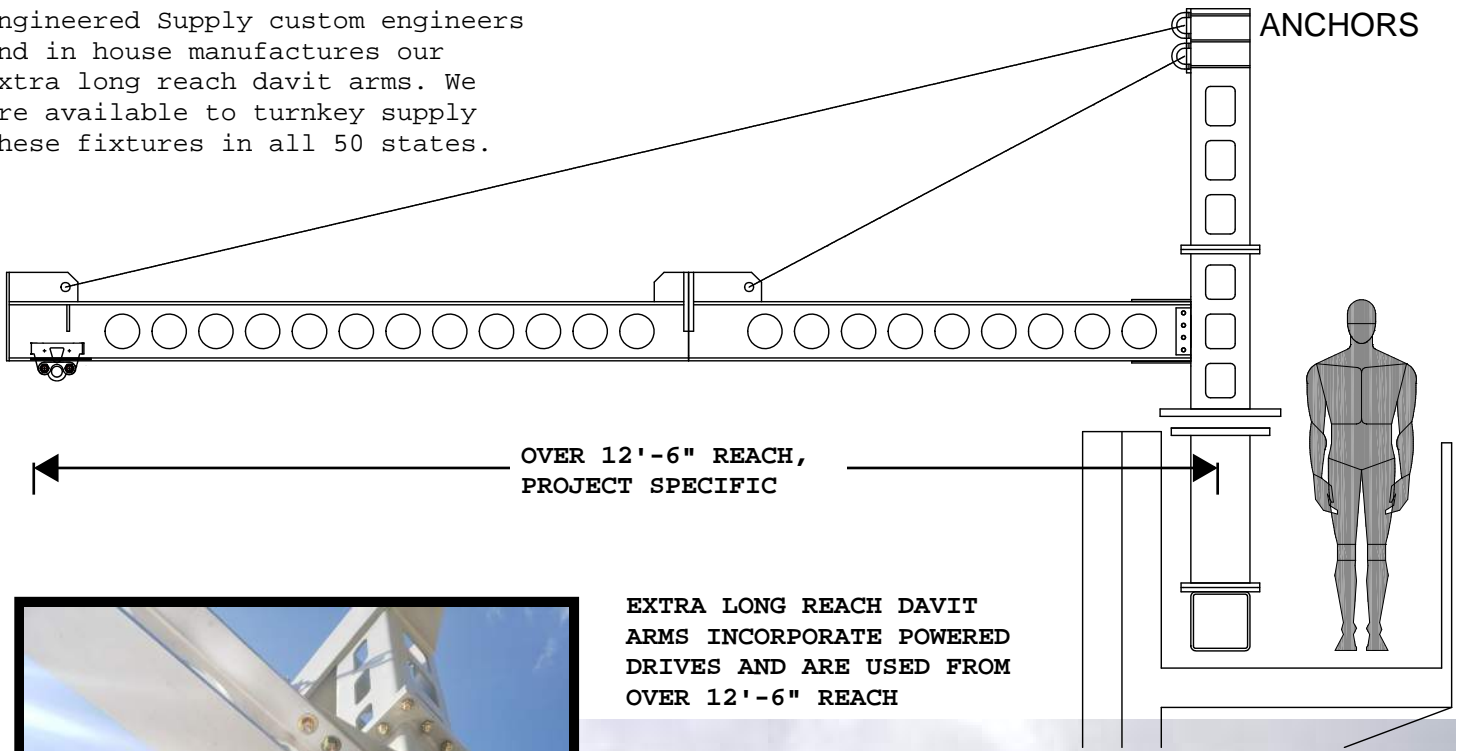

ANCHORS

ANCHORS



STORAGE POSITION



LIFTING POST

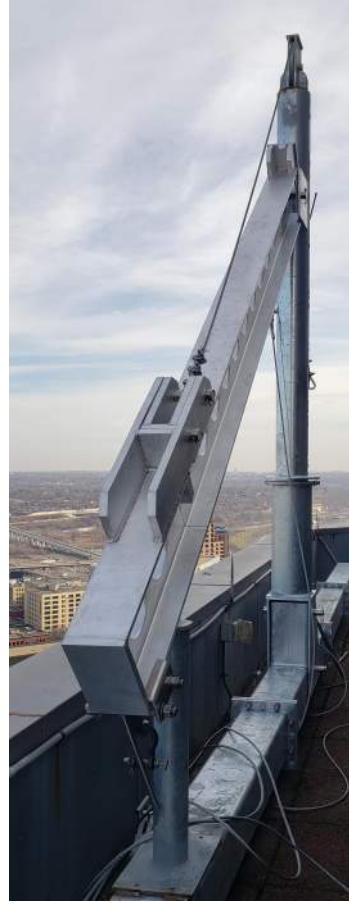

RAISING ARM



USE POSITION

Specialty davits are used when there is an obstruction preventing the arm from laying down.

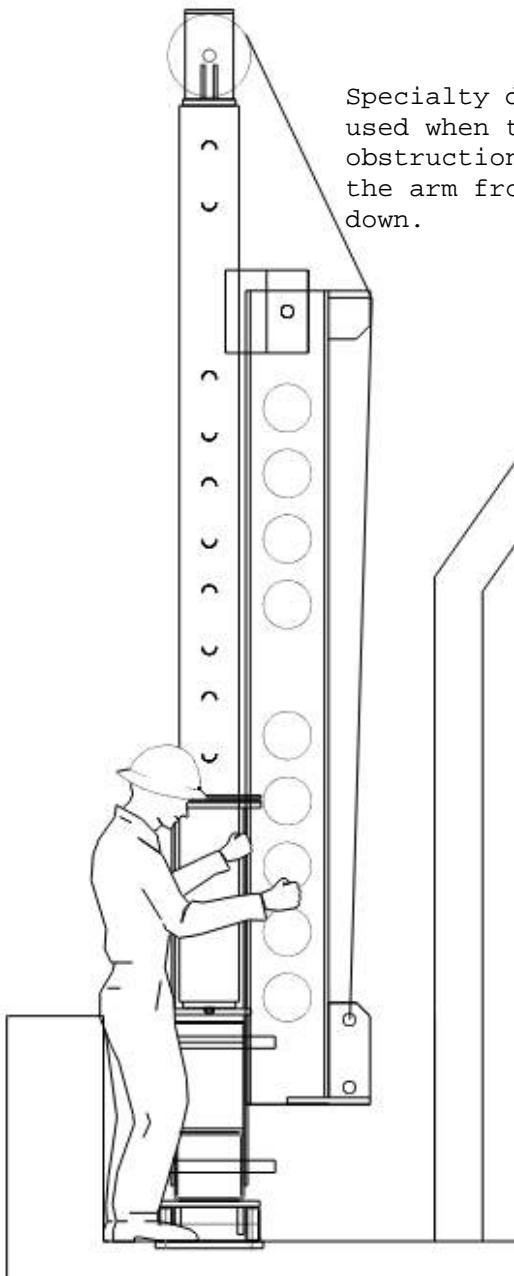

Engineered Supply custom engineers and in house manufactures custom davit arms of all types. We are available to turnkey supply these fixtures in all 50 states.



MATERIAL ARM

Material arms are typically light weight jib cranes that are used for transferring equipment from a higher roof to a lower roof. They commonly use the same davit base as the personnel arms. Note that buildings should have two personnel rated davit arms for every roof level they are used on (portable personnel davit arms should not be craned from roof to roof)



ES MANUAL DAVIT CARRIER

Engineered Supply engineers and in house manufactures custom davit carriers of all types. We are available to turnkey supply these fixtures in all 50 states.



Manual davit carriers are typically pushed along a structural track. Loose laid tracks are not commonly used for manual pushed davit carriers, as the amount of weight needed for stability would cause the unit to be difficult to push by hand.



ES POWERED DAVIT CARRIER

Powered davit carriers normally pick up the stage and translate it, however they are also used for ground launch and custom applications.

Powered davit carriers are also used where the track is loose laid (not tied directly to the structure) and weights are used for partial stability.



It is relatively common for Engineered Supply to work on legacy (older existing) carriers that are either removed and replaced, or have the legacy drive systems replaced with up to date equipment.



LEGACY POWERED DAVIT CARRIER

Engineered Supply understands anchorage connectors because we use them ourselves for rope descent, fall protection, fall restraint, tie back, direct suspension, and custom uses while we perform work at height installing our parts and working as a custom at-heights contractor. We regularly manufacturer staging for both permanent house rigs and transportable equipment and provide rental equipment to approved suspended maintenance contractors.



CORDLESS ROPE HOISTS THAT ES DISTRIBUTES



ES HOUSE STAGE UNDER FACTORY LOAD TEST WITH WIRE ROPE HOISTS THAT ES DISTRIBUTES



ES SINGLE MAN BASKET WITH CORDLESS ROPE HOIST



ES POWER BOATSWAIN CHAIR WITH CORDLESS ROPE HOIST

TRACK

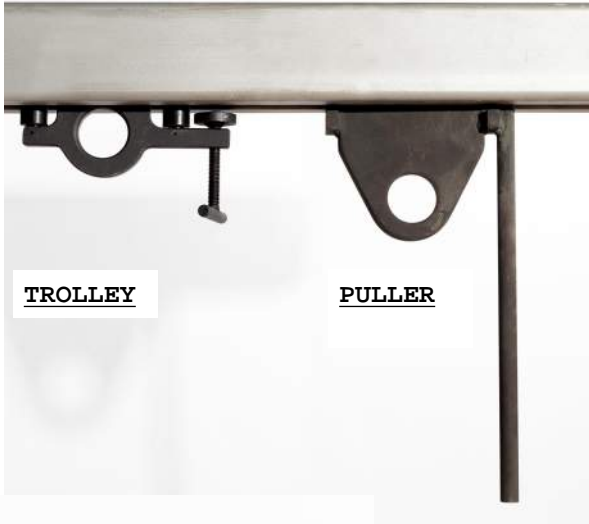

TROLLEY

PULLER



MONORAIL WITH RADIUS CORNERS



MONORAIL WITH TURNTABLE CORNERS



Monorails are commonly used when the building has an overhang that prevents a line dropped from the high roof being within a few feet from the glass / building facade.

Modern monorails are designed for two 5,000 pound loads per span (one from the puller and one from the trolley). Common spans are 10' and less for a 4" square reinforced monorail track. ES does not recommend aluminum monorail extrusions due to issues with differential thermal movement as well as fatigue and ductility considerations (once a monorail and its support structure is covered, they are difficult to visually inspect on a regular basis).

Engineered Supply custom engineers and in house manufactures monorails of all types. We are available to turnkey supply these fixtures in all 50 states.



RADIUS MONORAIL CORNER WITH PULLER AND TROLLEY

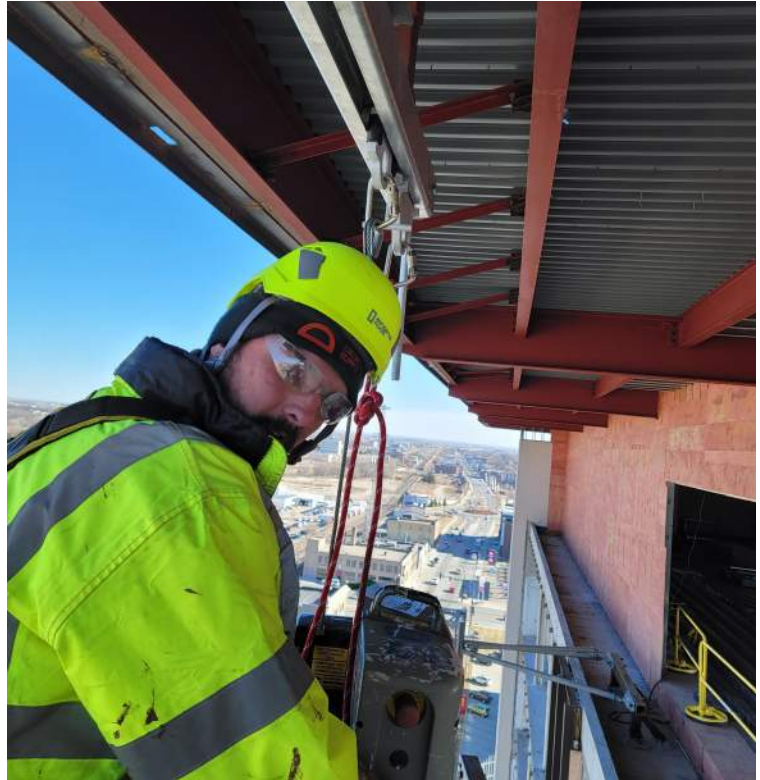

STANDING IN STAGE SUSPENDED FROM MONORAIL



MONORAIL TROLLEY WITH PULLER IN THE BACKGROUND



MONORAIL BEING SOFFETED IN



ANCHORS

ANCHORS

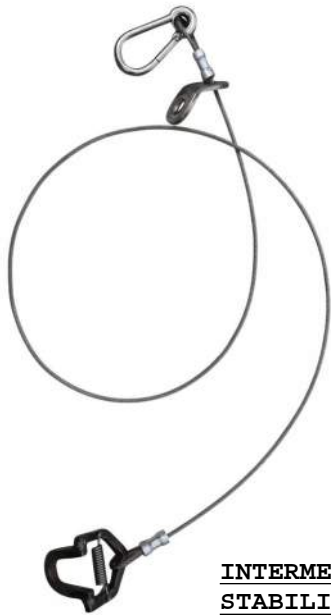

INTERMEDIATE
STABILIZATION
LANYARD (ISL)



BUILDING
ATTACHMENT HOOP
OF ISL FOR
BUTTON STYLE ISA



DETENT PIN STYLE ISA
(STAINLESS)

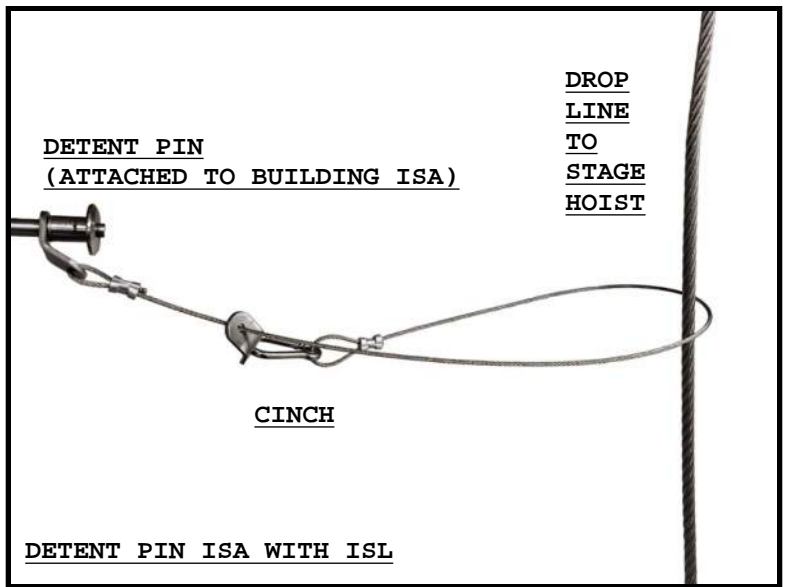

DETENT PIN
(ATTACHED TO BUILDING ISA)

DROP
LINE
TO
STAGE
HOIST

CINCH

DETENT PIN ISA WITH ISL



BUTTON TYPE
INTERMEDIATE
STABILIZATION
ANCHOR (ISA)

Intermediate Stabilization Anchors are required by OSHA on buildings over 130' in height. They are located at the drop cable location for swing stages, and spaced every three stories not to exceed 50' vertically.



BUTTON STYLE ISA
(NORTHERN USE)



DETENT PIN STYLE ISA
(SOUTHERN USE)

ANCHORS

SLOT STYLE
CONTINUOUS
STABILIZATION
ANCHOR (CSA)

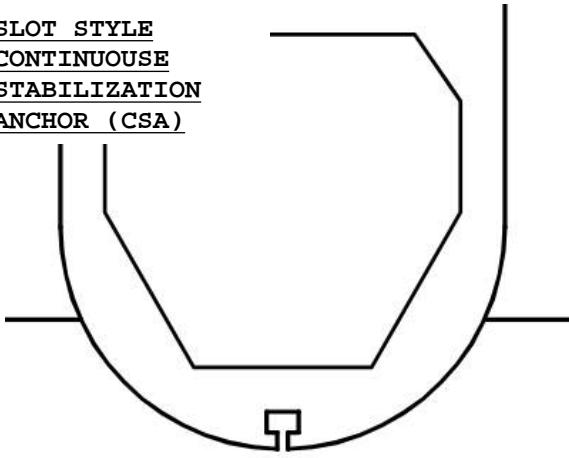

PRECAST T SLOT



STONE T SLOT



SLOT STYLE
CONTINUOUS
STABILIZATION
SLIDE
ATTACHED TO
STAGE

Continuous stabilization anchors are often found on buildings over 300' tall, and are common in cases when the building has a house rig (dedicated swing stage). They can allow for both roof launching and ground launching stages provided the slider can be inserted at the bottom. The slider always attaches to the stage. Fixed connections from the stage to slider are typical, however the slot track condition can be problematic after years of use. Lanyarded sliders are acceptable as well, but they require the operator to hand hold them when transversing.

ANCHORS

Engineered Supply custom engineers and stocks the components for ISAs and ISLs, as well as Continuous Stabilization Anchors. We are available to turnkey supply these systems in all 50 states.



CURTAINWALL T SLOTS



SLIDER LANYARD FOR T SLOT CSA



ANCHORS



ANCHORS



Engineered Supply stocks our Cablefuse Horizontal Lifeline Components, as well as our Bypass hardware. We are available to turnkey supply these systems in all 50 states.



Bypass Lifeline



Bypass Lifeline



Dual User Horizontal Lifeline from Gallows Arms



Dual Monorail Truss from Gallows Arms

Engineered Supply custom engineers and in house manufactures single point gallows arms, horizontal lifeline gallows arms, and monorail suspended from gallows arms. We are available to turnkey supply these fixtures in all 50 states.



ROLLING RIG



WEIGHTLESS OUTRIGGER

Engineered Supply custom engineers and in-house manufactures outrigger beams of all types. We are available to turnkey supply these fixtures in all 50 states.



DOWN AND UNDER PINNED OUTRIGGER



AROUND THE GUTTER PINNED OUTRIGGER LAUNCHED

ANCHORS



PORTHOLE OUTRIGGER

ANCHORS



OVERHEAD PORTHOLE OUTRIGGER



HIGH REACH OUTRIGGER



EXTRA LONG REACH OUTRIGGERS



LONG REACH OUTRIGGER



ANCHORS

ANCHORS



THERMAL INSULATION MATERIAL



PROPER VAPOR BARRIER PLACEMENT

Engineered Supply has always provided custom options and additions for anchorage connector systems. We are able to meet or beat any specification.



100% 304 or 316 STAINLESS STEEL ANCHORAGE CONNECTORS AVAILABLE FOR CUSTOM ORDER



OPTIONAL CLOSED CELL SPRAY FOAM INSULATION FILLING AT PIPE ANCHORS

ANCHORS

ANCHORS



EPDM



STOVE
PIPE



TPO



LIGHTNING
PROTECTION



PITCH
POCKETS



METAL
ROOFS

Engineered Supply products are compatible with all roofing system.



IRMA /
GREEN
ROOFS



GREEN
ROOFS

ANCHORS

Anchorage Connector Loading Considerations

Knowing that the acceleration of gravity at the surface of the earth is 32 feet per second each second a peak fall velocity can be attained using a 6 foot fall distance and the equation $V=(2a(x))^{0.5} = 19.7 \text{ ft/s}$.

The time elapsed to fall six feet is 0.6 seconds which is too fast for a human to react and to be able to grab something (which is why we sometimes fall).

Understanding that a common harness and lanyard stretch is around two feet, which is the deceleration distance we can arrive at a deceleration $= v^2/(2*d) = 97 \text{ ft/s}^2$

Using the common equation $F = ma = 310 \text{ lbm} * 97 \text{ ft/s}^2 = 30,070 \text{ lbm ft / s}^2$. Knowing that one pound force is equal to $32.2 \text{ lbm / ft / s}^2$ we take 30,070 and divide it by 32.2 to arrive at a force of 933 pounds force applied to a 310 pound mass user falling for six feet and then decelerating over a common two foot lanyard stretch.

It is common for ANSI Z359 rated fall protection equipment to put an average force of less than 900 pounds to the user.

So why do we commonly design anchorage connectors for 5,000 pounds force? For one, because accidents at height don't always have a shock absorbing lanyard involved. Consider that a common web lanyard with no shock absorber stretches around four inches after a six foot fall, we arrive at an astonishing deceleration $= v^2/(2*d) = 582 \text{ ft/s}^2$ which equates to a force of 5,603 pounds force. This much force applied to an anchorage connector with a calculated design strength of 5,000 pounds would likely survive this applied impact load and may have some cracking or loosening.

Another reason for the 5,000 pounds is that a rope descent user places less than 1,000 pounds service load onto an anchorage connector while using rope descent. Common anchorage connectors are rated to 1,250 pounds service load because of this. Equipment carrying personnel is required to have a minimum factor of safety of four to breaking, which results in 5,000 pounds minimum breaking strength of the anchorage connector.

The third reason is very similar, it is typical to use 1,000 pound hoists for swing stages. Allowing some weight for the wire rope and rigging above the hoist that travels with this stage leads us to the same 1,250 times a factor of safety of four equals 5,000 pounds minimum breaking strength of an anchorage connector.



RDS USER WEIGHTED TO 310 POUNDS WITH LOAD CELL ON 1/2" STATIC KERNMANTLE ROPE

1,000 POUND FORCE
IMPACT LOAD

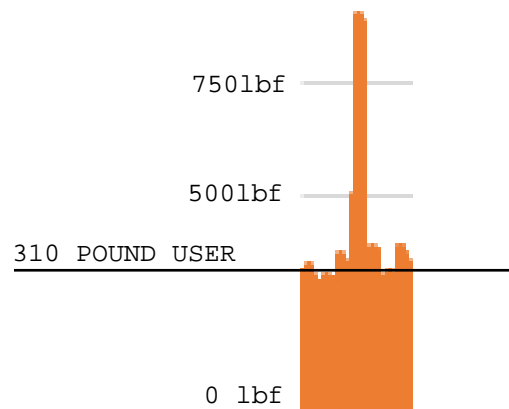
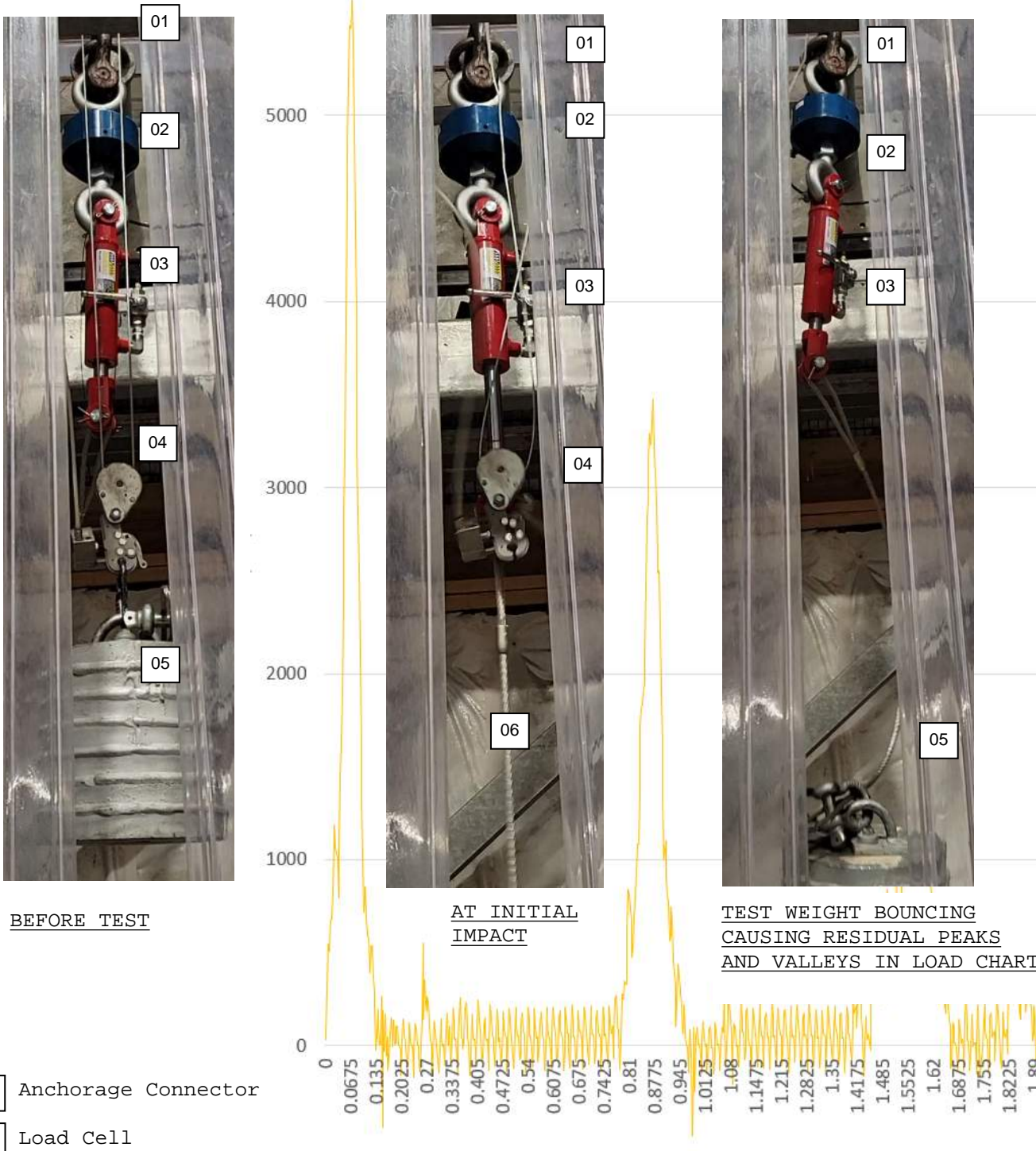

Figure A1

Force [lbf] verse Time for a "short stop" using RDS with 310 pound user.

Model Building Codes such as the International Building Code (IBC) take a similar approach, except the equations they use are not geared to impact load and breaking load. Their calculations consider design strength with a load factor (factor of safety) of 1.6 for most controlling live load combinations, and sometimes give approximately 5,000 pounds divided by 1.6 = 3,125 pounds live load. While important for engineers to understand the 3,125 pound load for appropriately combining with other things such as wind, this 3,125 pound load is not derived from an actual service event.



BEFORE TEST

AT INITIAL IMPACT

TEST WEIGHT BOUNCING CAUSING RESIDUAL PEAKS AND VALLEYS IN LOAD CHART

01 Anchorage Connector

02 Load Cell

03 ANSI Z359.18-T Dynamic Qualification Testing Shock Absorber

04 Pneumatic Quick Release

05 Test Weight, 282 lbm set at a fall height of 3'

06 Wire Rope Lanyard

Figure A2

Force [lbf] verse Time [s] from a ANSI Z359.18-T Anchorage Dynamic Qualification Test





Tall Ladder on a Tall Building



Custom Portable Spreader Beams between Existing Davit Bases for Rope Descent



Stairways to Heaven

Engineered Supply has always provided custom miscellaneous metals including stairs, railings, ladders, platforms, bridges, and light structural steel.



Permanent Railing Systems



Custom Access Systems



Traveling Gantries



Monument Stairs



Bridges and Platforms





AT HEIGHTS WELDING



SUPERVISED SUPPLY-ONLY PROJECTS WITH THE GENERAL CONTRACTOR'S LABOR FORCE

We have been installing thousands of anchors each year for the last decade. Our details are proven to be the most compliant and easiest to install time and time again by the standard design bid build process. We run our own engineers, our own designers, fabricate in our own shop with materials bought from the same reliable suppliers, truck with our own fleet of vehicles, and install with our own tools. Take advantage of our long track history of successful products and details by including us on your team.



TURNKEY INSTALLATION PROJECTS

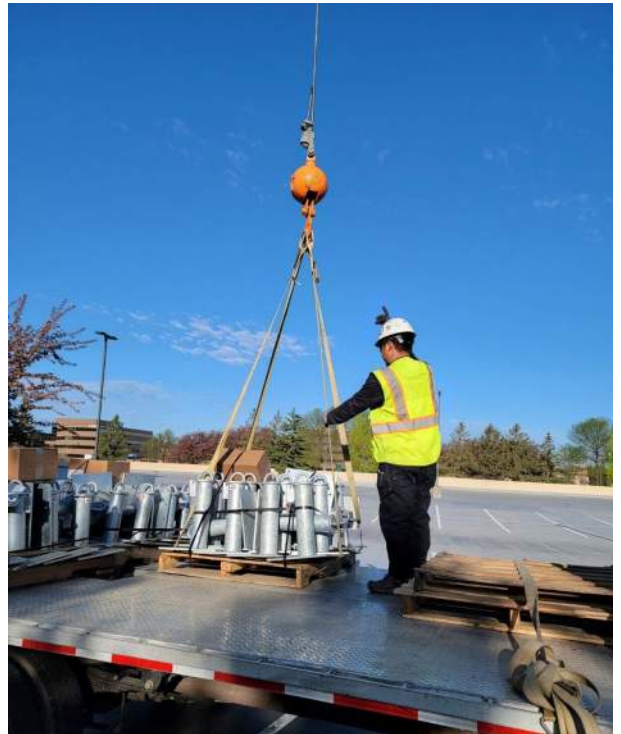

ALL PALLETIZED MATERIAL SENT FROM OUR WAREHOUSE IS READY FOR THE CRANE.



At Engineered Supply we manufacture our stocked StrongTop anchors to the strict requirements of all the applicable standards including OSHA, International Building Code, and ANSI Z359.18-T by the thousands. We pass this volume savings on to you, and can easily match or beat any competitor's list price.



MANUFACTURED
IN
MINNESOTA

MADE AND MELTED
IN THE U.S.A.

All our anchorage connectors are manufactured at our own shop in our home State of Minnesota by our in-house certified welders who make anchorage connectors full time.

We take it a step further and make sure that all the mild structural steel in our stock anchorage connectors is melted and rolled in the United States of America.



**ENGINEERED
SUPPLY®**

EQUIPMENT MANUAL

SUSPENDED MAINTENANCE ANCHORAGE CONNECTORS

SECTION THREE

Layout

Engineered Supply provides anchorage connector layouts, and reviews existing layouts for compliance. This section includes information for standard anchorage connector layout, and examples of common custom layout scenarios.

New Construction Anchor Layout

Window washers use rope descent for washing windows on mid and high rise buildings. Anchorage connectors should be provided for buildings with nominally four building levels of vision glass and buildings with vision glass having an elevation 30' or higher as measured from the grade to the top of the vision glass unless restricted by other applicable provisions (such as the roof having a drop height greater than 300' where rope descent is not typically allowed).

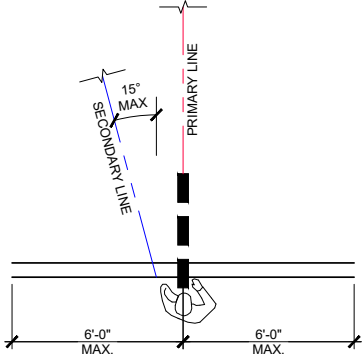

NEW BUILDING ROPE DESCENT TIE-BACK ANGULATION

- 01 Primary Line
- 02 Secondary Line
- 03 User with harness, shock absorbing lanyard, and rope grab attached to secondary line

Newly constructed buildings compliance with the requirement of "In Line" is easily done during the design phase of the building. Anchors shall be placed in line to the work area so as to prevent displacement of lines under load and/or a fall greater than 6 feet. Placement of anchors shall not be within 6 feet of the roof edge unless fall protection is provided to access those anchors safely. In no case shall anchor spacing exceed 12 feet. The risk to the worker is greatly reduced by placing the anchors further back from the roof edge, but not so far that the line may contribute to a fall more than 6' or to a swing fall.

Unless at a building corner, or other building geometry that requires it, anchors shall be placed no less than 12 feet from the leading edge and no more than 50 feet to the leading edge. Anchors shall have the ability to compliantly approach and access them.

Engineered Supply generally states that a window washer can reach 6' in one direction with a 3' arm holding a 3' long squeegee. This idealization is to reduce the possibility of a swing fall, or going across the face of the building in an uncontrolled swing like Tarzan.

Historically, anchorage connectors were placed at about 20' on center along the building length at approximately the middle of the roof. The rope descent user was then forced to swing over and suction cup off to reach the vision glass, which is difficult or impossible near the top of the building (the line angle is too steep to pull over the 10'). This is why we have a general requirement of placing the anchors at no more than 12' on center.

Window washers prefer to drop on the mullion when possible. Using the approach given for new buildings the anchorage connector layout does not need to take this into consideration, as the system user will be able to adjust the drop line over to their preferred location.

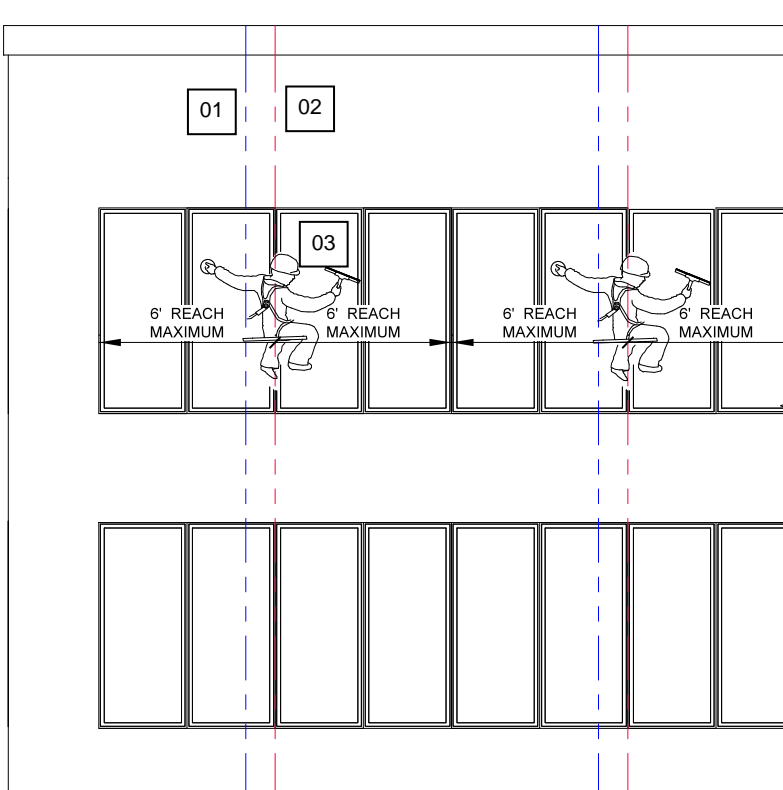

BUILDING ELEVATION

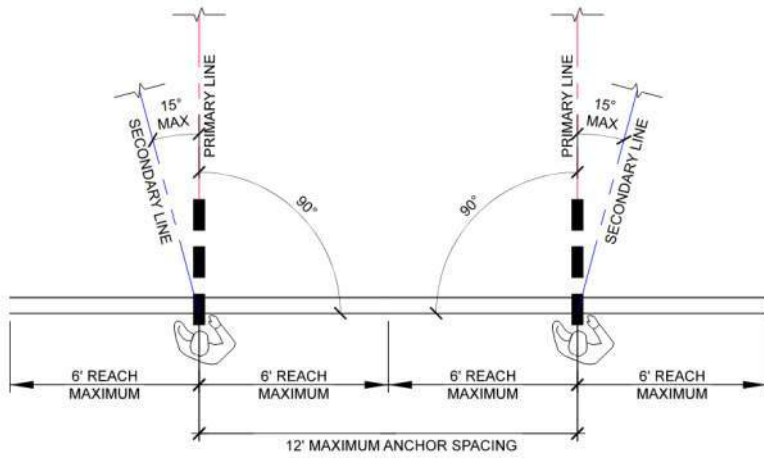

**NEW BUILDING ROPE DESCENT
TIE-BACK ANGULATION**

New Construction Anchor Layout

Using the 12' on center maximum, and the 15 degrees, the most economic location for anchors is 45' from the roof edge (15 degrees and 45' ends up with a 12' spacing geometrically).

The maximum distance to locate anchors from the roof edge is 50'. The reasons that anchors are located at 50' or less is to reduce the amount of rope on the roof (if your anchors are hundreds of feet back from the roof edge, the rope tends to stretch too much when getting into the chair). Secondly it provides a reasonable limit so that future rooftop equipment does not interfere with the usability of anchorage connectors.

Anchorage connectors shall not have multiple lines attached to the same anchorage connector simultaneously unless specifically rated as such by a licensed engineer.

When laying out anchors, it is permissible to use them in multiple ways understanding that the user will not tie more than one line to the same anchorage connector. Refer to the figure on the right, showing one anchorage connector receiving four lines (note this won't occur in the field simultaneously).

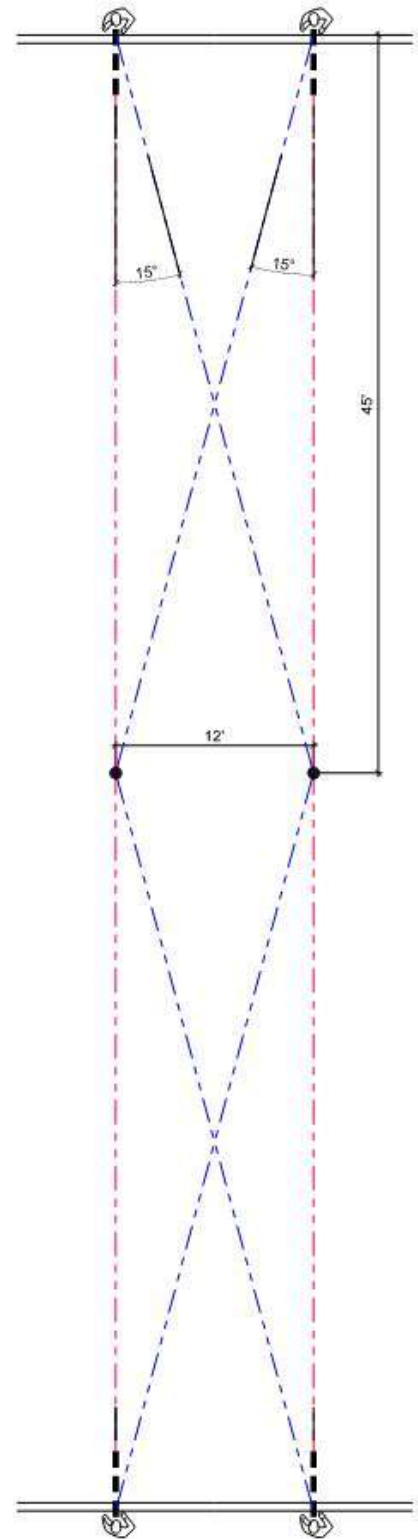

**NEW BUILDING
ROPE DESCENT
TIE-BACK
ANGULATION**



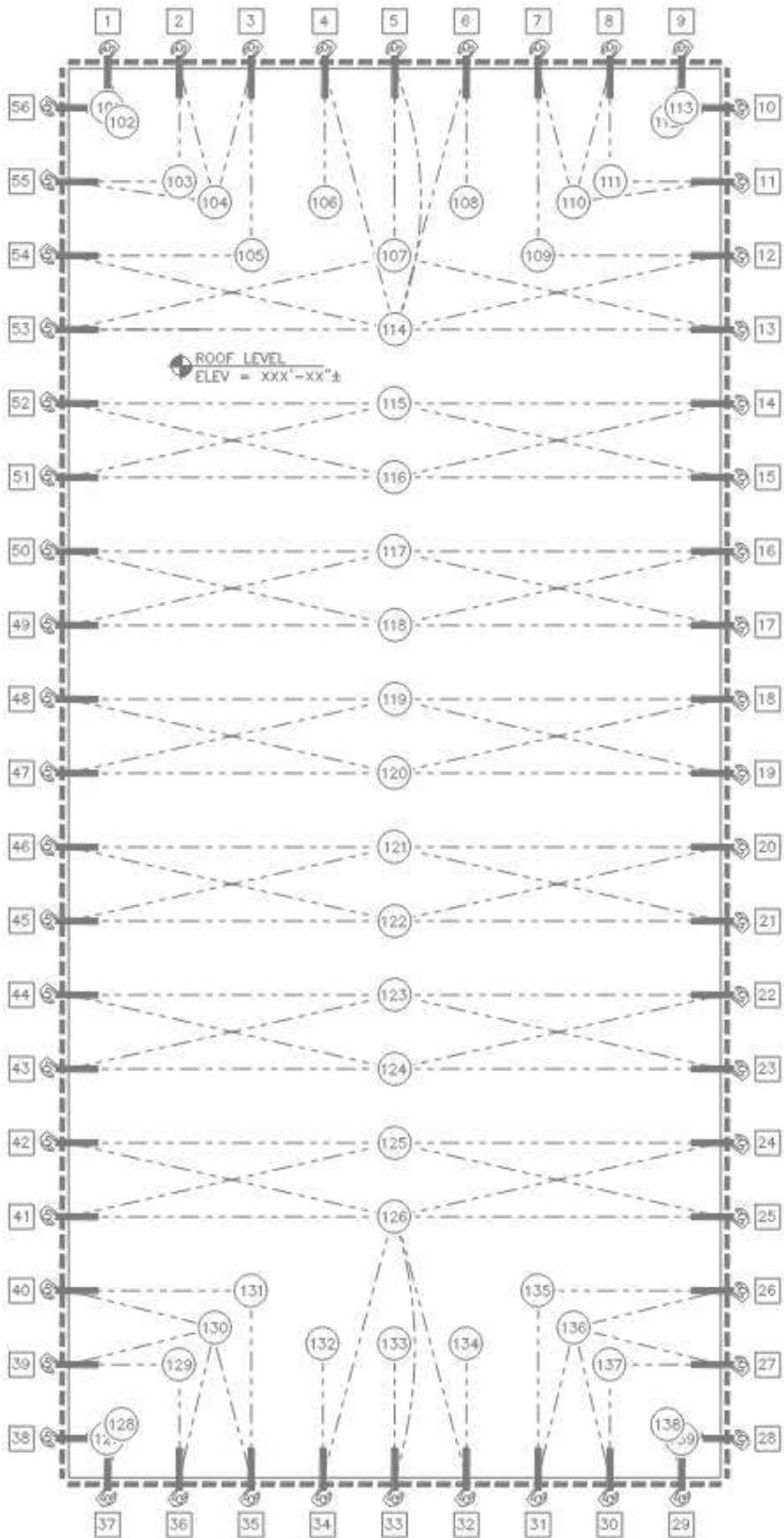

Typical Anchor Layout for Continuous Glazing On Rectangular Building

Layouts should have the roof elevation given in feet above the ground level for assisting in planning out rope lengths and which statutes apply.

Specifically note that at the corners, the user must reach out 6' to the edge of the building. It is very dangerous to have a large amount of rope out near a corner and in no case is a setup where the rope could slip over the building corner allowed.

The number and location of the drops should be indicated. Plans just showing the anchors without intended usage are very confusing and can easily lead to setups that do not comply with the system design intent.

Anchorage connectors should be numbered on the print and in the field. Engineered Supply stamps them after inspection and load test as an additional quality control (if they have been stamped, they are acceptable for use at ES).



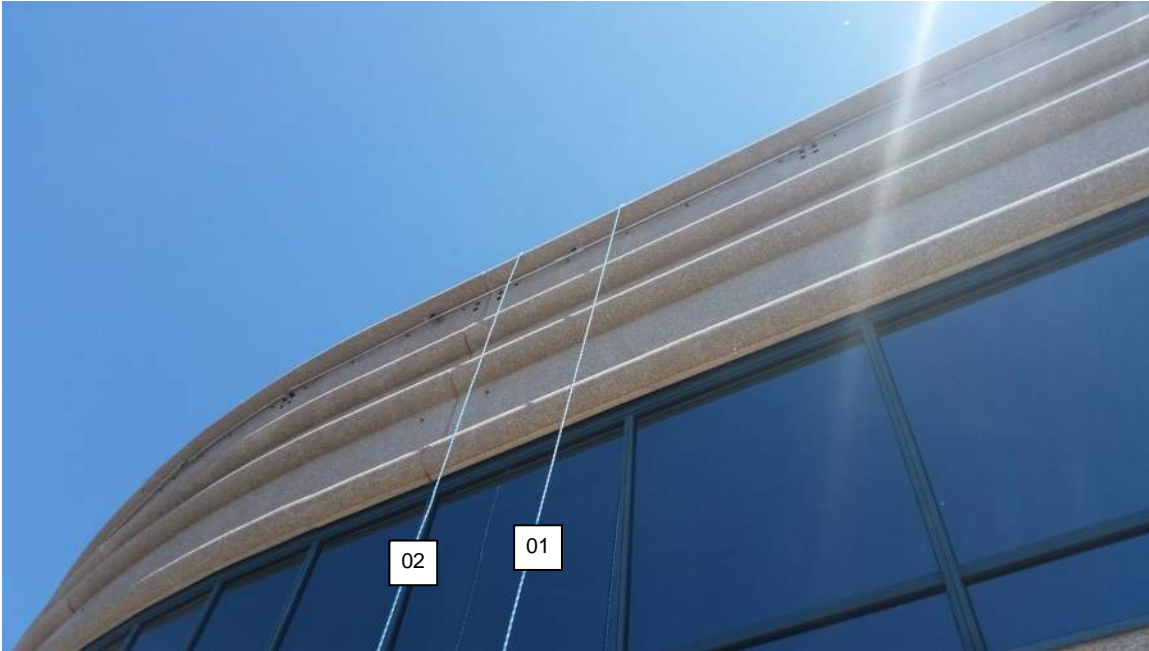

- 01 Primary Line
- 02 Secondary Line

View Looking up From a Chair

LAYOUT PROCEDURE ROPE DESCENT,
 -NO PINNED BEAMS WITH PARAPET SIZED FOR PRIMARY LINE LOAD [OR]
 -WEIGHTED OUTRIGGER BEAMS WITH PARAPET NOT SIZED FOR PRIMARY LINE LOAD

Locate windows requiring access on a plan view.

Start in each of the corners locating the drops.

An Anchorage Connectors row will typically run in a 45 degree angle from a main building corner.

When two lines of anchorage connectors meet they run across the building parallel to the length.

For joists and beam roofs, anchorage connectors typically will center on framing below to reduce the cost of Secondary Structure.

Where obstructions occur add anchorage connectors.

Typically allow 1'-6" minimum from a face of building wall and 2'-0" between anchorage connectors so that the roof can be properly flashed.

Several iterations may be required to determine ideal and economical layout.



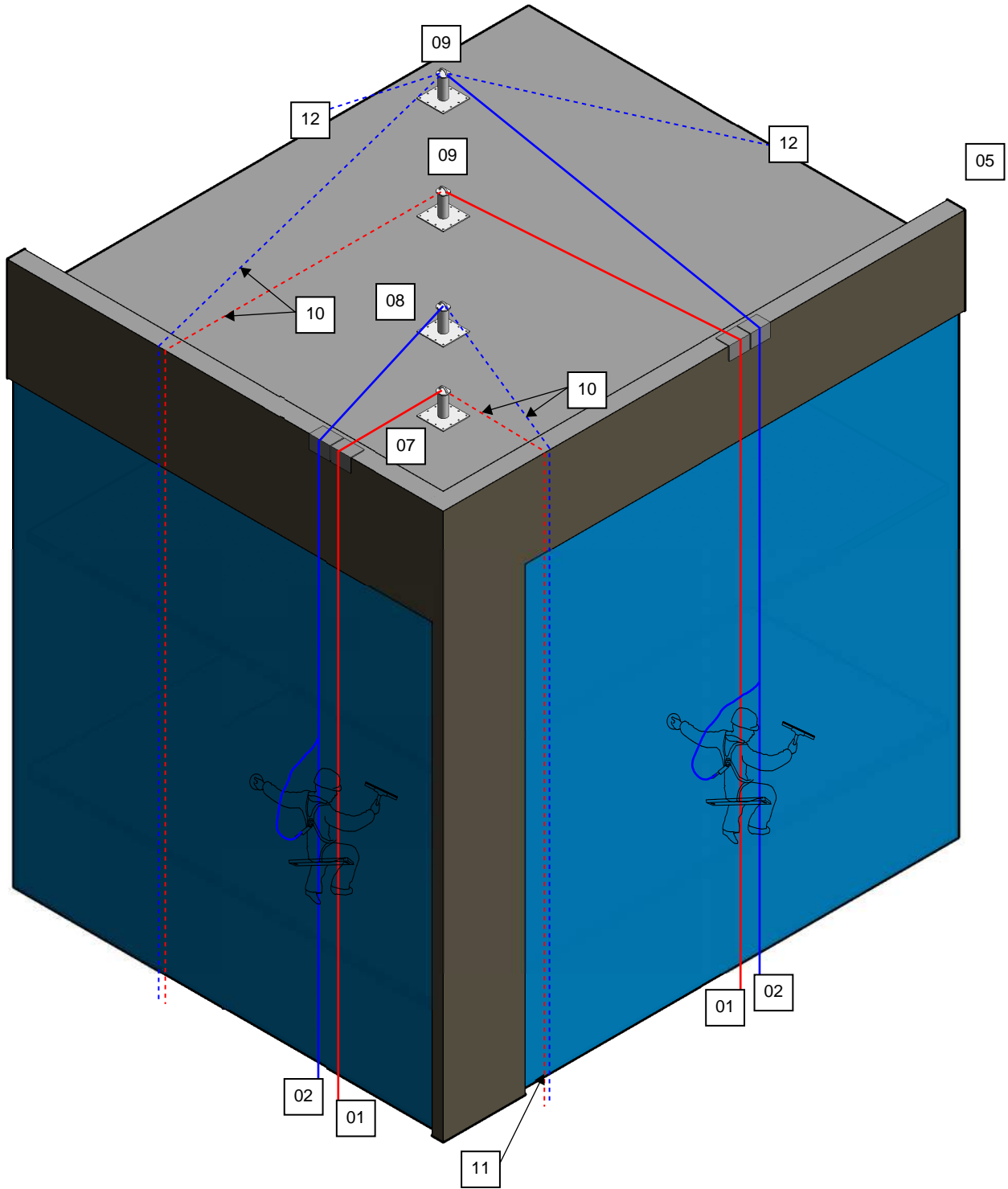

- 01 Primary Line
- 02 Secondary Line
- 03 User with harness, shock absorbing lanyard, and rope grab attached to secondary line
- 04 Anchorage connector
- 05 Passive protection, 42" or taller parapet walls for edge fall protection
- 06 Edge protection for secondary line
- 07 Corner anchorage connector, locate 6' in from edge of glass for rope descent layouts. Locate 6' in from corner of building for layouts that use swingstage. Provide consideration for building maintenance.
- 08 Second corner anchorage connector, Locate 8' in from edge of glass for rope descent layouts. Locate 8' in from corner of building for layouts that use swingstage. Provide consideration for building maintenance if a rope descent only layout is provided.
- 09 Other corner anchorage connectors will be spaced by drop locations and Secondary Line angulation. In no case shall anchors be spaced more than 12' on center.
- 10 Anchorage connectors will be used for multiple faces of the building, but not simultaneously for washing purposes.
- 11 Geometry will not always allow for the drops to center on a mullion. For continuous curtainwall on new buildings with anchorage connectors not exceeding 12' on center this is not of concern (if mullion drops are required the user may choose to drop using a different sequence and following these rules will allow for adequate anchorage connector coverage).
- 12 As the distance from the roof edge to the anchorage connector increases, it will be possible to use an anchorage connector for one drop's primary line and the adjacent drops secondary line. The user will not hook two lines to one anchorage connector simultaneously.



LAYOUT

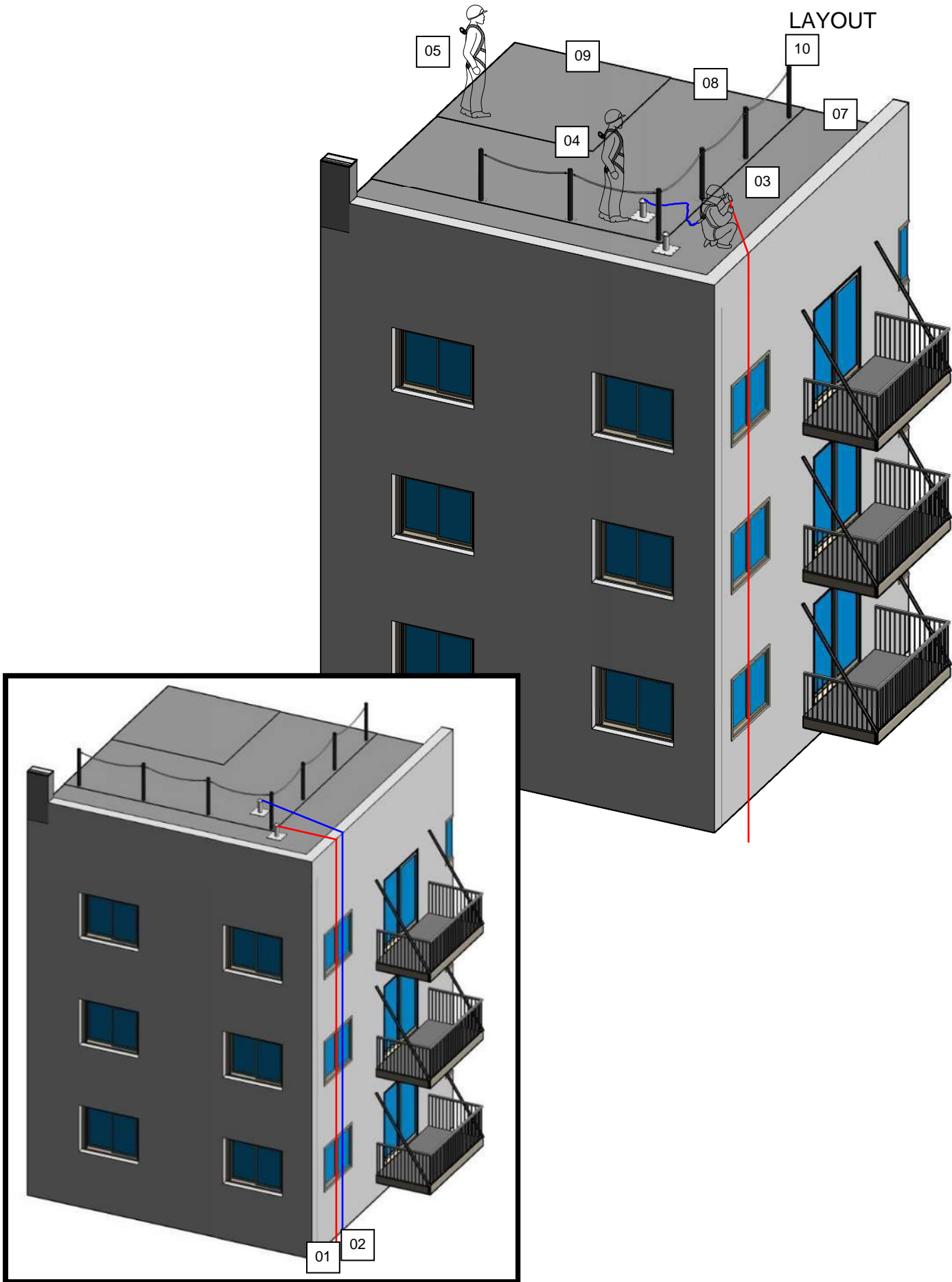

- 01 Primary Line
- 02 Secondary Line
- 03 User less than 6' from roof edge with harness, shock absorbing lanyard, and carabiner attached to anchorage connector
- 04 User with warning line at 6' but closer to 15' from roof edge
- 05 User with no fall protection system more than 15' from roof edge
- 06 Anchorage Connector
- 07 When work is performed less than 6 feet (1.6 m) from the roof edge, the employer must ensure each employee is protected from falling by a guardrail system, safety net system, travel restraint system, or personal fall arrest system.
- 08 When work is performed at least 6 feet (1.6 m) but less than 15 feet (4.6 m) from the roof edge, the employer must ensure each employee is protected from falling by using a guardrail system, safety net system, travel restraint system, or personal fall arrest system. The employer may use a designated area when performing work that is both infrequent and temporary.
- 09 When work is performed 15 feet (4.6 m) or more from the roof edge, the employer must: Protect each employee from falling by a guardrail system, safety net system, travel restraint system, or personal fall arrest system or a designated area. The employer is not required to provide any fall protection, provided the work is both infrequent and temporary; and implement and enforce a work rule prohibiting employees from going within 15 feet (4.6 m) of the roof edge without using fall protection.
- 10 Personal fall arrest system or travel restraint systems shall be used while setting up a designated area if available. If none is available, it is acceptable to set up a designated area without provided no work is completed within 6' from the roof edge.



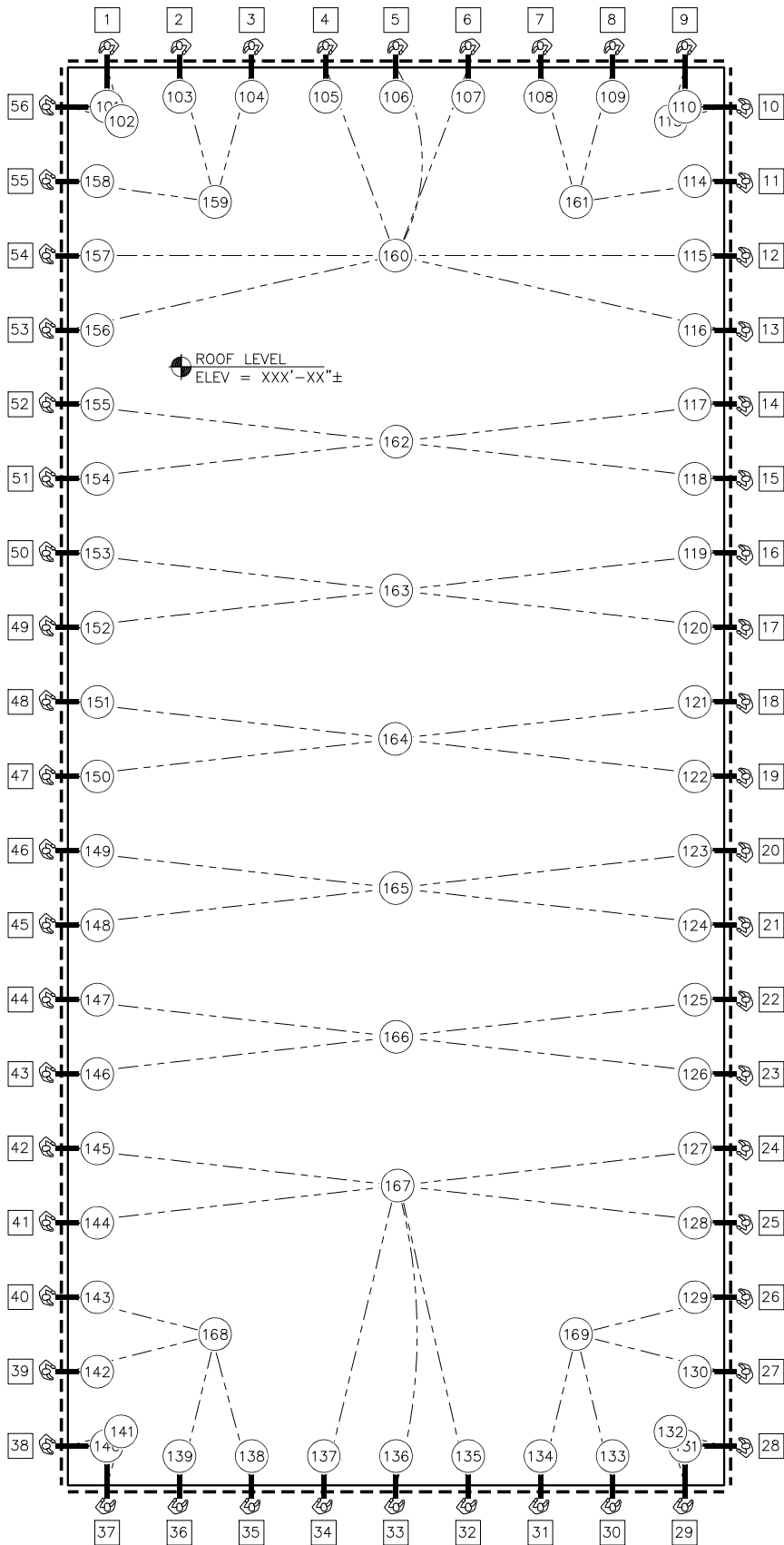

Typical Anchor Layout for Continuous Glazing On Rectangular Building Using a Pinned Outrigger Approach (common in California)

If the parapet wall is not designed for the rope load, or rope descent is not common or not allowed (such as in the case of specific buildings or users that meet certain criteria in the states of California and New York) it is more common to use a swingstage or power rope ascender hoist with a single man basket to wash windows.



POWER ASCENDER

When a hoist is used, the primary drop line must be held out from the face of the building by 1' to 2' (commonly 1'6") so that the hoist does not run into the face of the building as the user nears the top (Rope descent devices are not much larger than the rope and this offset from the face of the building is not required for RDS).

Note that this ends up with 67x anchors in comparison to the 37x anchors shown on page 3 for a standard RDS layout.



TYPICAL RIGGING FOR HIGH PARAPETS WITH PINNED OUTRIGGER BEAMS
(NO COUNTERWEIGHTS USED)



TYPICAL RIGGING FOR STANDARD PARAPETS WITH PINNED OUTRIGGER
BEAMS (NO COUNTERWEIGHTS USED)



Horizontal Life Lines shall not be used for Primary Line Support

In areas that have less than 6' of walking distance from the edge of the roof to the anchorage connector and the typical secondary structure cannot reasonably support two anchorage connectors because of geometrical and / or strength constraints it is acceptable to use a properly designed horizontal life line for attachment of the secondary line. Note that bypass systems and shock absorbers that actuate at low line loads shall not be used for supporting the secondary line.

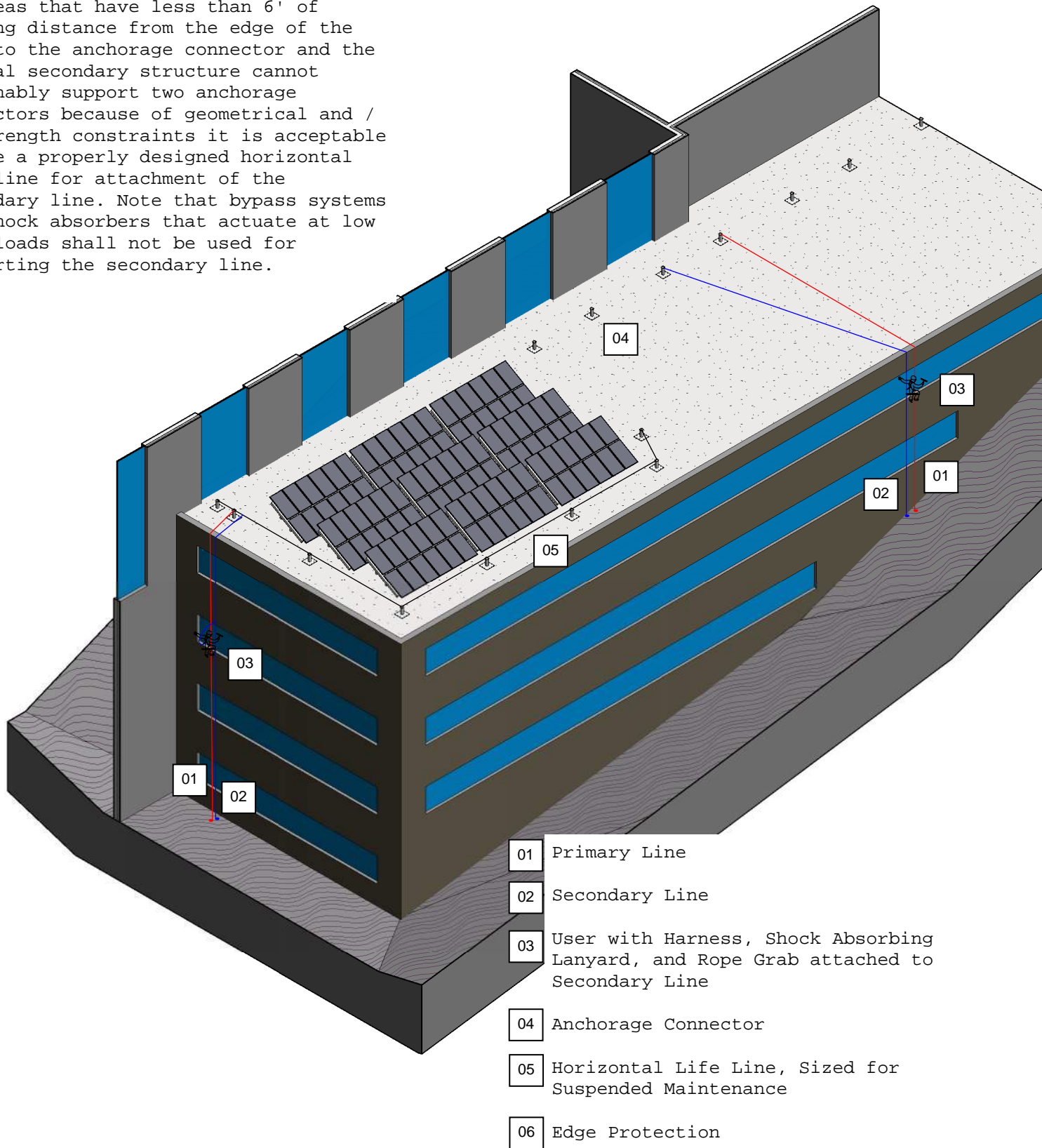

- 01 Primary Line
- 02 Secondary Line
- 03 User with Harness, Shock Absorbing Lanyard, and Rope Grab attached to Secondary Line
- 04 Anchorage Connector
- 05 Horizontal Life Line, Sized for Suspended Maintenance
- 06 Edge Protection

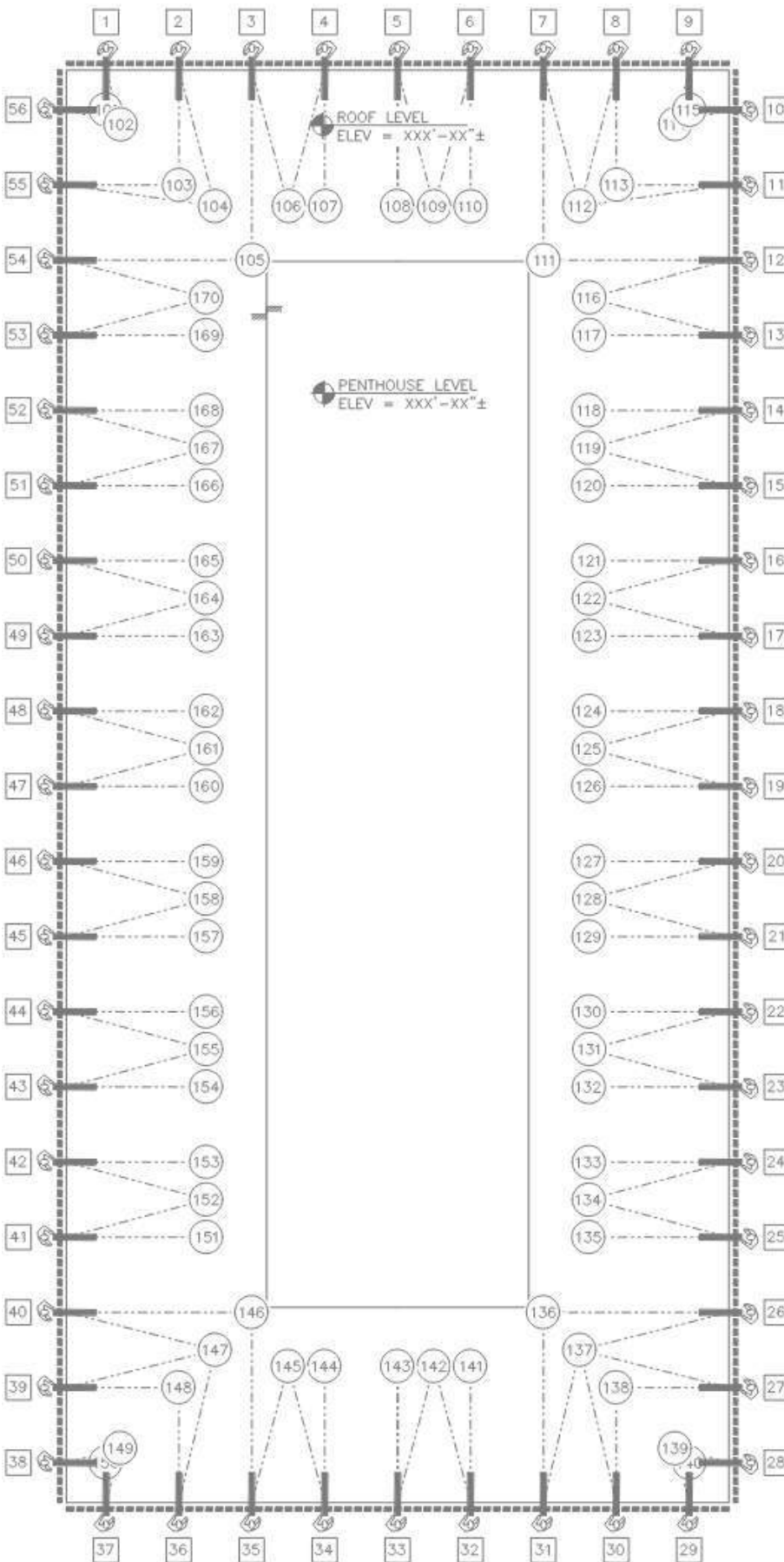

Penthouses, solar panel arrays, or similar obstructions that stop the lines from servicing both faces of the building typically result in a layout similar to the one shown here.

Note that this layout has 70x anchors in comparison to the 37x anchors shown on page 3 for a standard RDS layout.

LAYOUT

- 01 Primary Line
- 02 Secondary Line
- 03 User with harness, shock absorbing lanyard, and rope grab attached to secondary line
- 04 Anchorage Connector
- 05 Passive Protection, 42" or taller parapet walls for edge fall protection
- 06 Edge Protection for Secondary Line

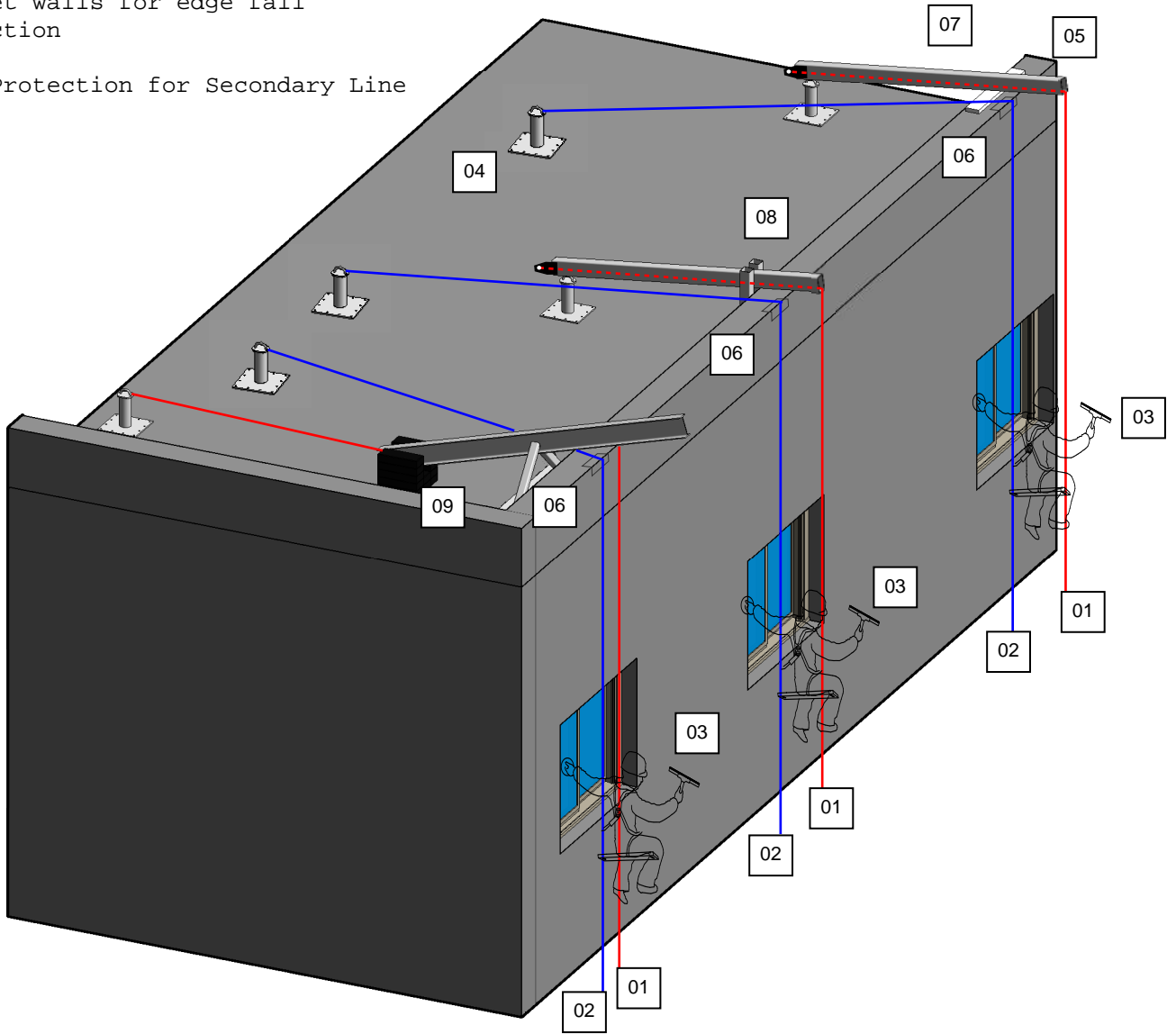

- 07 Pinned outrigger beam bearing on parapet wall (parapet wall sized for vertical load)
- 08 Pinned outrigger beam bearing on stand
- 09 Counterweighted outrigger beam with tieback

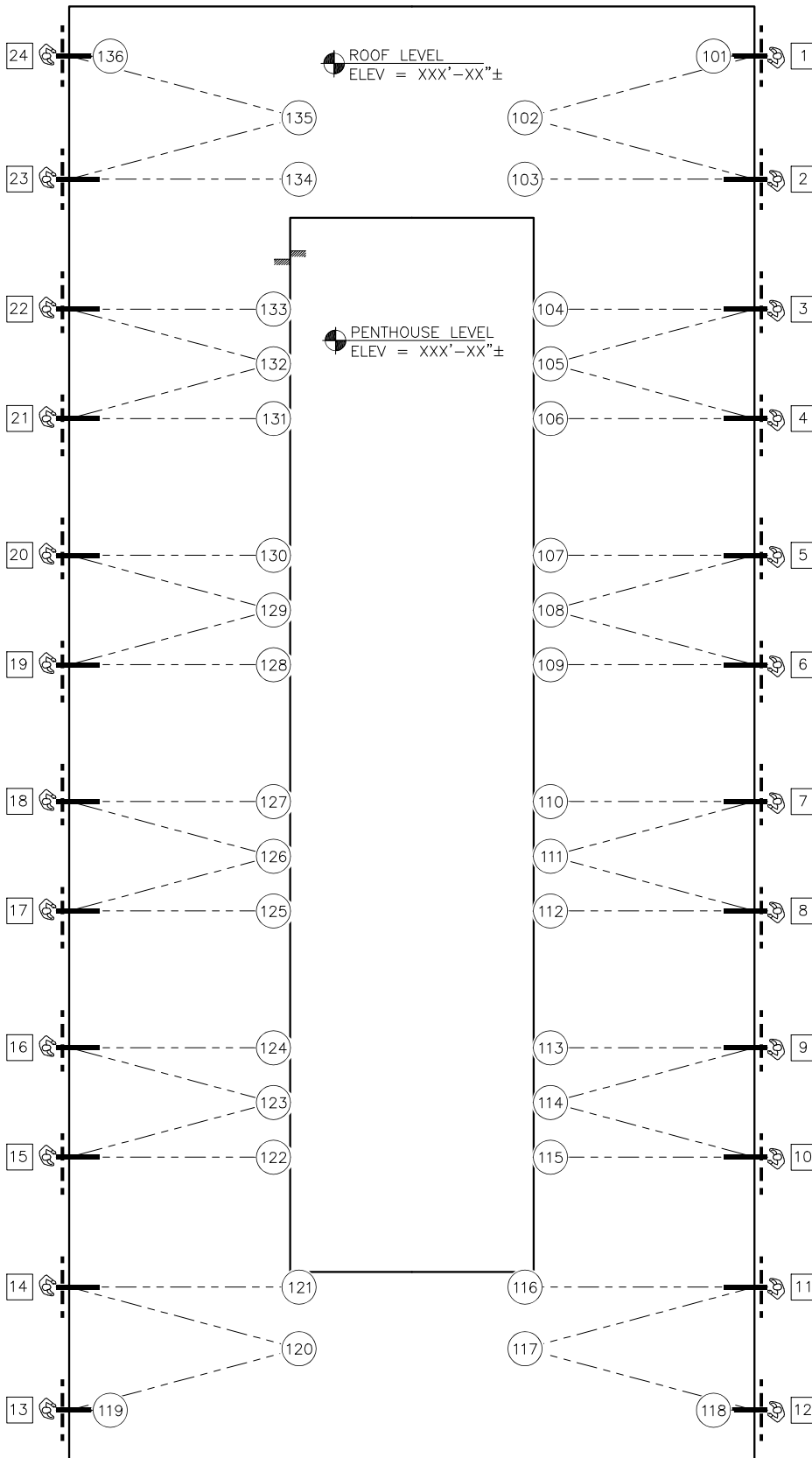

Rope descent is typically not used where there are not windows (most other activities such as tuck pointing and glass replacement require a swing stage which has different requirements).

In the case of punched openings, the anchors need to be located so that the edge of the vision glass can be reached. Note that anchors at 12' on center are not required for the full perimeter, as some locations do not have drops.

This layout shows a building that is well over 100' wide, so the ropes cannot go to a central anchor location and meet the required maximum 50' setback (so the ends have two rows of anchors even though the ropes could go to a central anchor location).

Note that even with the building being wider, addressing just the punched window locations reduced the anchor count to 35x in comparison to the 70x shown on the previous page 12 for a building with continuous glazing around its perimeter.



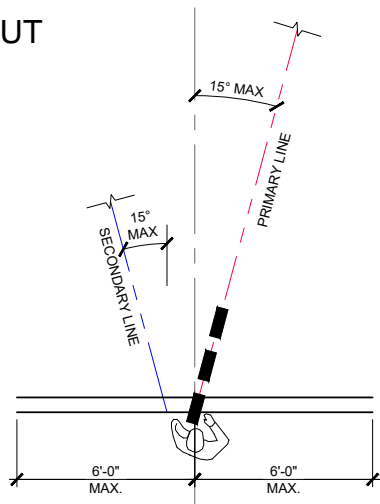

EXISTING BUILDING ROPE DESCENT TIE-BACK ANGULATION

Using this method of primary line angulation severely reduces the system user's options for where the primary drop line can go. As the existing mullion locations are known on an existing building the system designer should endeavor to place drops on mullion locations (mullion locations often are not reliably known on new buildings during initial layouts)

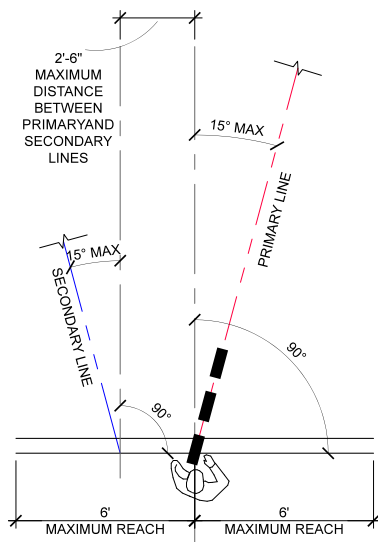

EXISTING BUILDING ROPE DESCENT TIE-BACK ANGULATION WITH SPACED PRIMARY AND SECONDARY LINES

Existing Buildings

The installation or identification of anchorages on existing buildings will vary from that of new buildings. The safety of the worker(s) shall be of utmost importance when designing an anchor system to be installed on an existing building.

Anchors shall be placed in line with the suspended worker unless this is impractical as judged by the professional engineer overseeing the layout, anchorage connectors may be offset on existing buildings no more than 15 degrees from In Line without a tag line and a space not exceeding 2'-6" be allowed between the primary and drop line.

- Here are examples of common impractical conditions:
- If placed in line the anchorage connectors cannot be supported by the primary structure's calculated capacity at the ideal drop location.
 - The anchorage connectors are required to be placed 6' or closer of the leading edge.
 - The geometry of the typical secondary structure will not allow the anchorage connector placement.
 - Existing anchorages are already there and the building is not being re-roofed.

These allowances shall not be permitted if displacement of the rope under load could create a swingfall condition.

These allowances are not justified in an effort to reduce anchorage counts simply to save budget / money.

It is acceptable to use the allowances for coordination issues that arise during the construction of new buildings, but not during the planning of new building anchorage connector systems.

In legacy anchorage connector systems, where the roof is not being opened, Engineered Supply judges adding up to a 2'-6" space between the primary and secondary line acceptable.

Additional anchorages shall be placed to improve this situation when the roof is next replaced (roof replacement exposes the primary structure and gives an opportunity to improve the situation).

In no case shall the anchor spacing exceed 12'.

This example of an angled primary line shows 42x anchors which can in general be compared to the 70x anchors for an "in-line" system shown on page 12 (this is actually a building in the Minneapolis, MN area that had a legacy anchorage connector system). In this job the drops were not able to line up with the mullions, as there was not enough anchors - however there is a precast ledge between each window band that the user can brace their feet against so it was judged acceptable.

In this case, Engineered Supply would recommend additional anchors are installed during the next re-roof but not require them to be added if the Owner took exception to them because of the past use.

For reference, in the last century this building was washed with rope descent using no anchorage connectors using a window washers parapet hook with no secondary life line and no tie back.

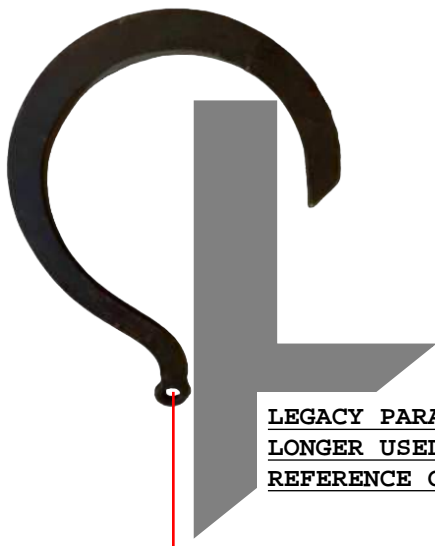
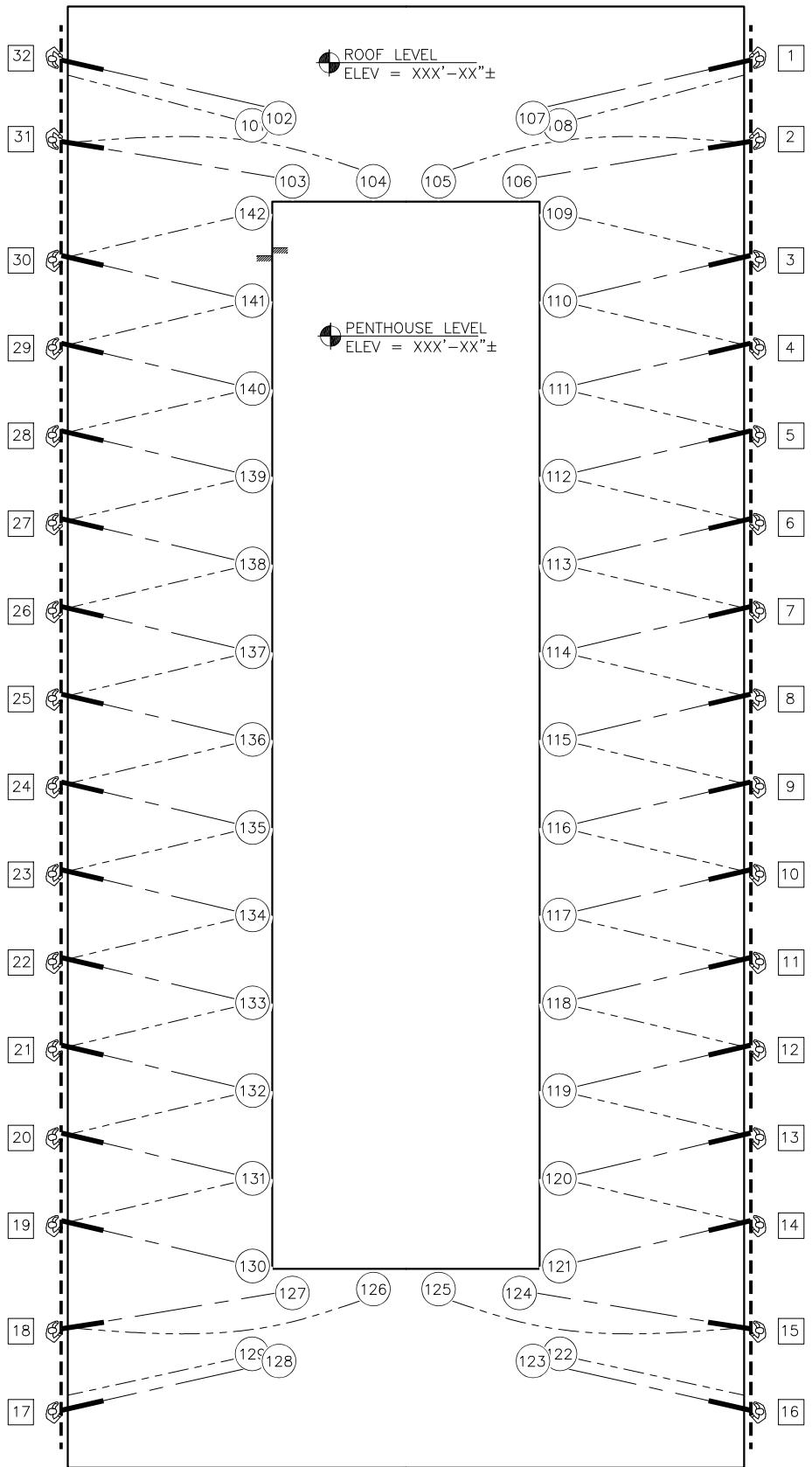

LEGACY PARAPET HOOK (NO LONGER USED, FOR REFERENCE ONLY)



Swingstage primary and secondary lines shall extend to safe landing surface below.

Edge protection shall be provided at all Line contact locations.

Typically rigging sleeves and davit arms are located on column spacings (main grid lines).

Transportable stages are lighter construction and can span up to 40' without specialty equipment (built for non constant use and made to carry easily from building to building).

House rigs (building dedicated swingstage) are typically heavier and span in the 30' range.

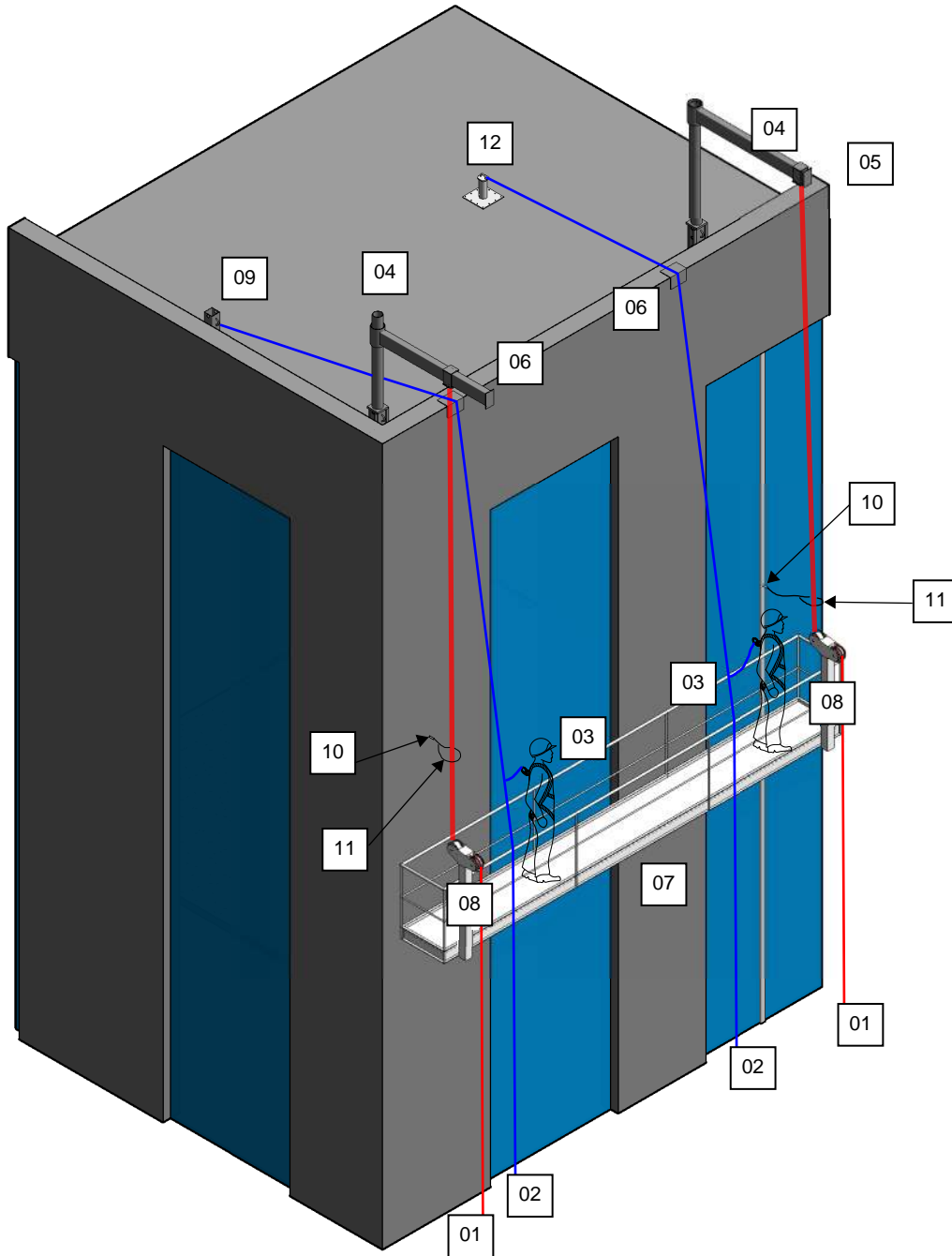

Note:
 sometimes
 corner arms
 are run longer
 to accommodate
 end stirrups
 on the stages.
 The stage
 shown has a
 walk through
 stirrup, which
 is heavier and
 sometimes not
 available.

- 01 Primary Line
- 02 Secondary Line
- 03 User with harness, shock absorbing lanyard, and rope grab attached to secondary line
- 04 Anchorage connector, rotating davit base for roof launch or fixed arm for ground rigging.
- 05 Passive protection, 42" or taller parapet walls for edge fall protection
- 06 Edge protection for secondary line
- 07 Swing stage, roof launched or ground rigged
- 08 Hoist
- 09 Anchorage connector, davit base with compatible anchorage connector eye
- 10 Intermediate Stabilization Anchor
- 11 Intermediate Stabilization Lanyard
- 12 Anchorage connector, pipe anchor with base plate

- 01 Primary Line
- 02 Secondary Line
- 03 Tieback Line
- 04 Plate Anchorage Connector
- 05 Pipe Anchorage Connector
- 06 Vertical Rigging Sleeve
- 07 Parapet Clamp with Tieback for Primary Line
- 08 Parapet Clamp for Secondary Line (note typically no tieback)

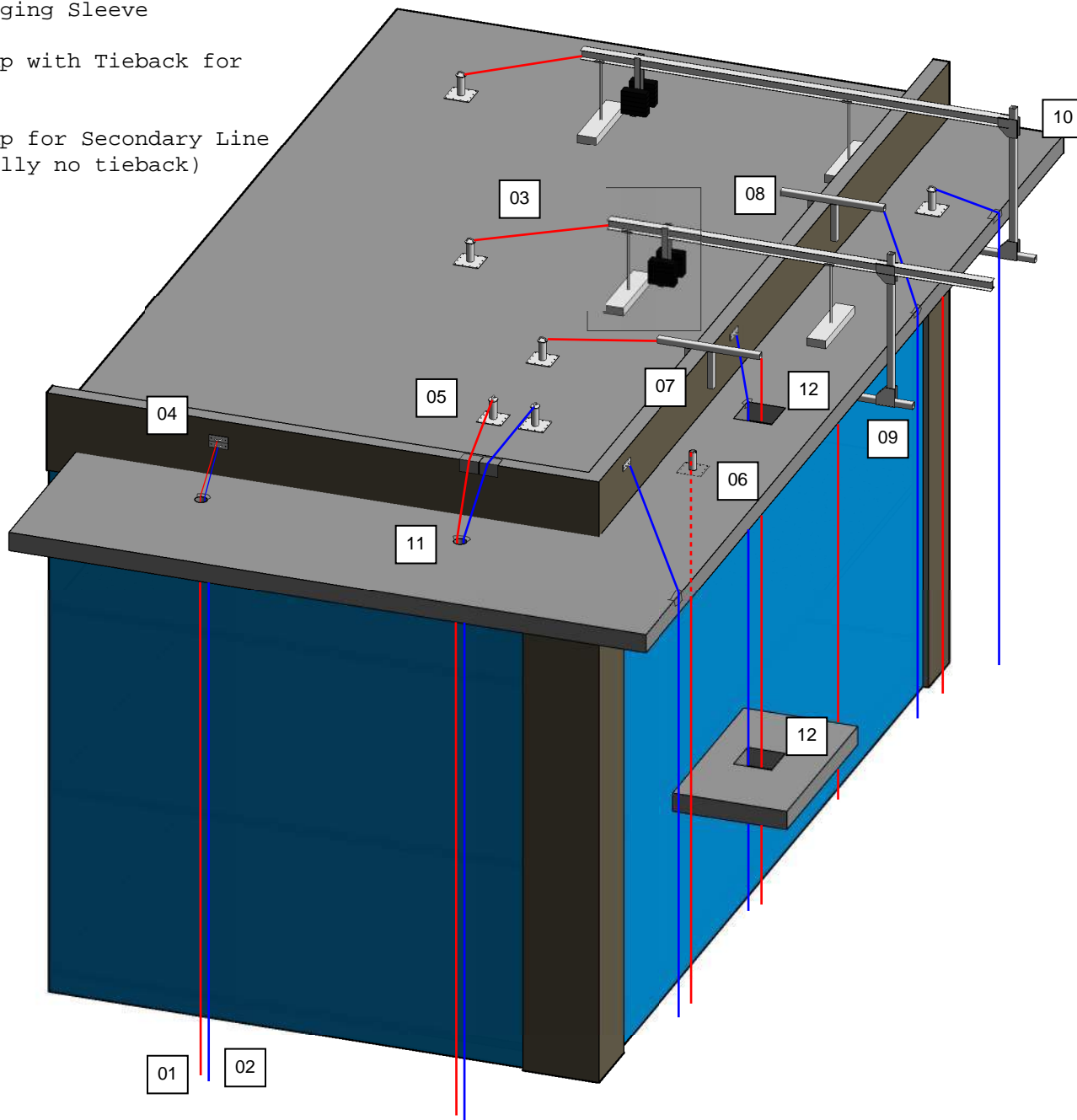

- 09 Counterweight Beam with a Down and Under (C style end, sometimes called a reach around beam)
- 10 Long Reach Counterweight Beam (for locations where outcropping does not have capacity to support)
- 11 Rigging Hole (sometimes called a pigeon hole)
- 12 Personnel Opening (sometimes called a hatch)

- 01 Primary Line
- 02 Secondary Line
- 03 User with harness, shock absorbing lanyard, and rope grab attached to secondary line
- 04 Pipe Anchorage Connector
- 05 Horizontal Rigging Sleeve
- 06 Outrigger Beam with Trolley
- 07 Personnel Opening (Hatch)
- 08 Ladder
- 09 Work Platform
- 10 Single Man Basket

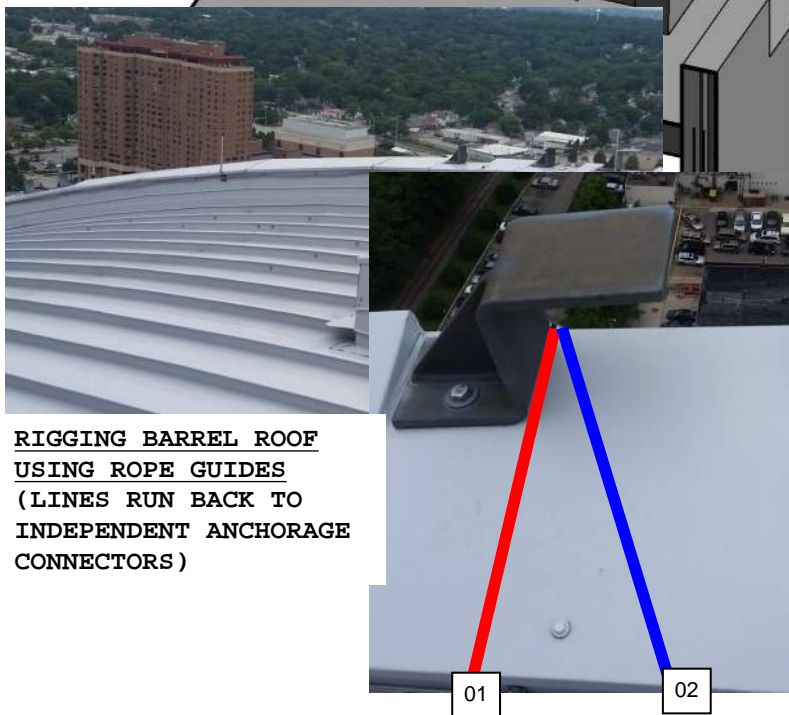
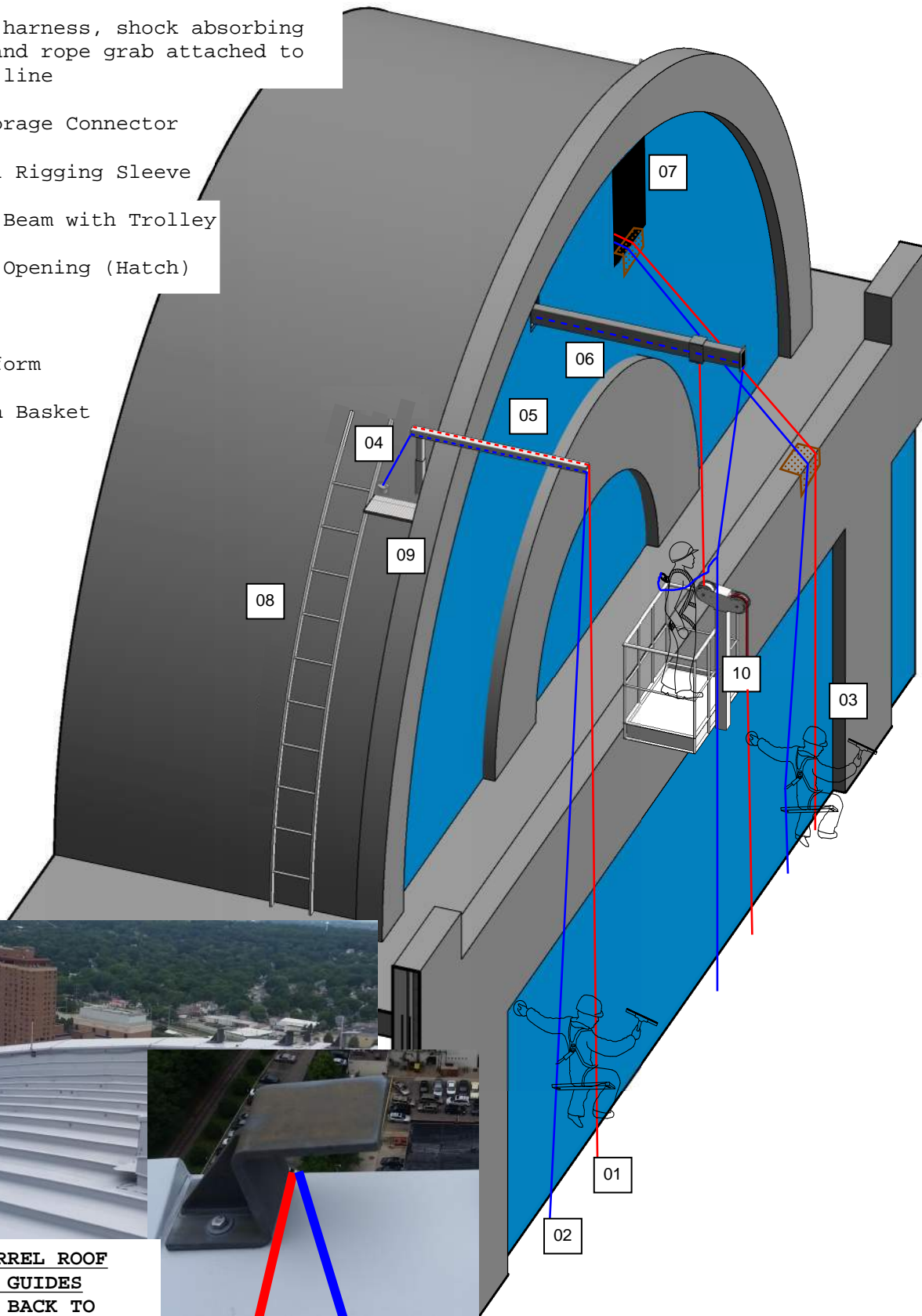

**RIGGING BARREL ROOF
USING ROPE GUIDES
(LINES RUN BACK TO
INDEPENDENT ANCHORAGE
CONNECTORS)**

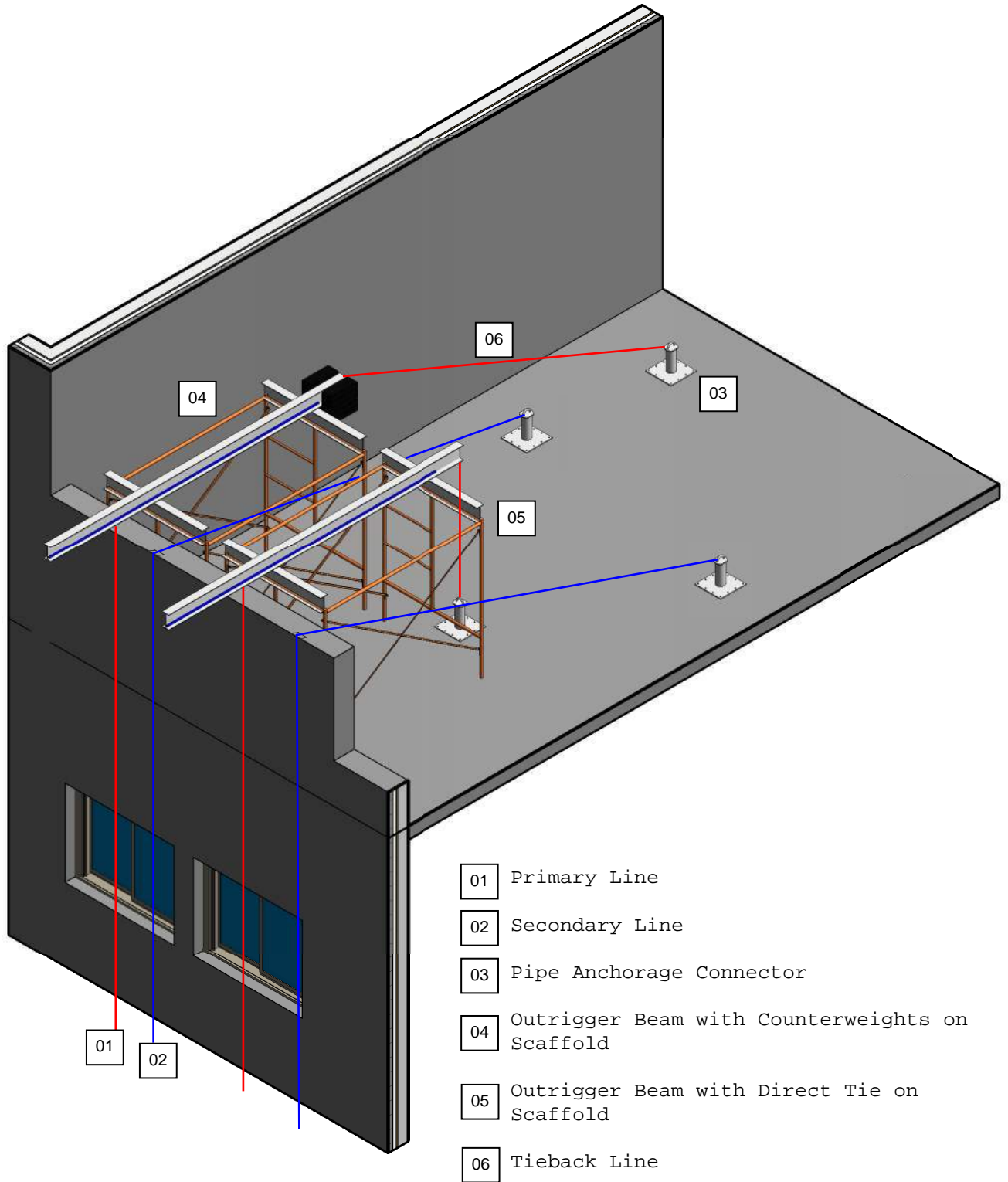

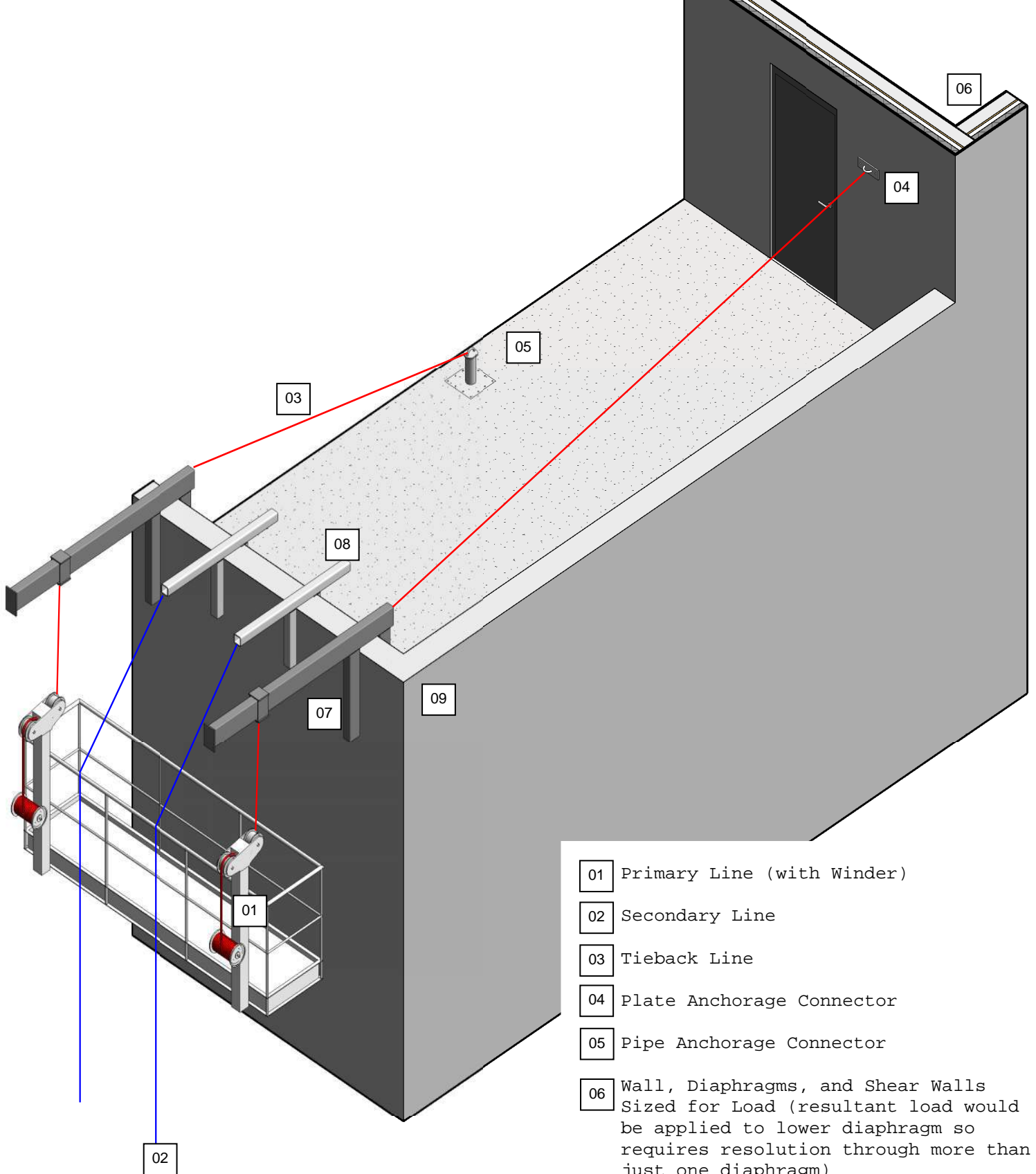

- 01 Primary Line
- 02 Secondary Line
- 03 Anchorage Connector, Monorail Trolley
- 04 Anchorage Connector, Monorail Puller
- 05 Access Panel to Monorail
- 06 Anchorage Connector, Vertical Rigging Sleeve
- 07 Monorail

Depending on geometry, it may be possible to have a drop adjacent to the monorail and rig the trolley and puller from the adjacent drop and omitting the access panel. Mid air transfers are no longer recommended, not all washers will complete them, however they still occur on legacy systems.

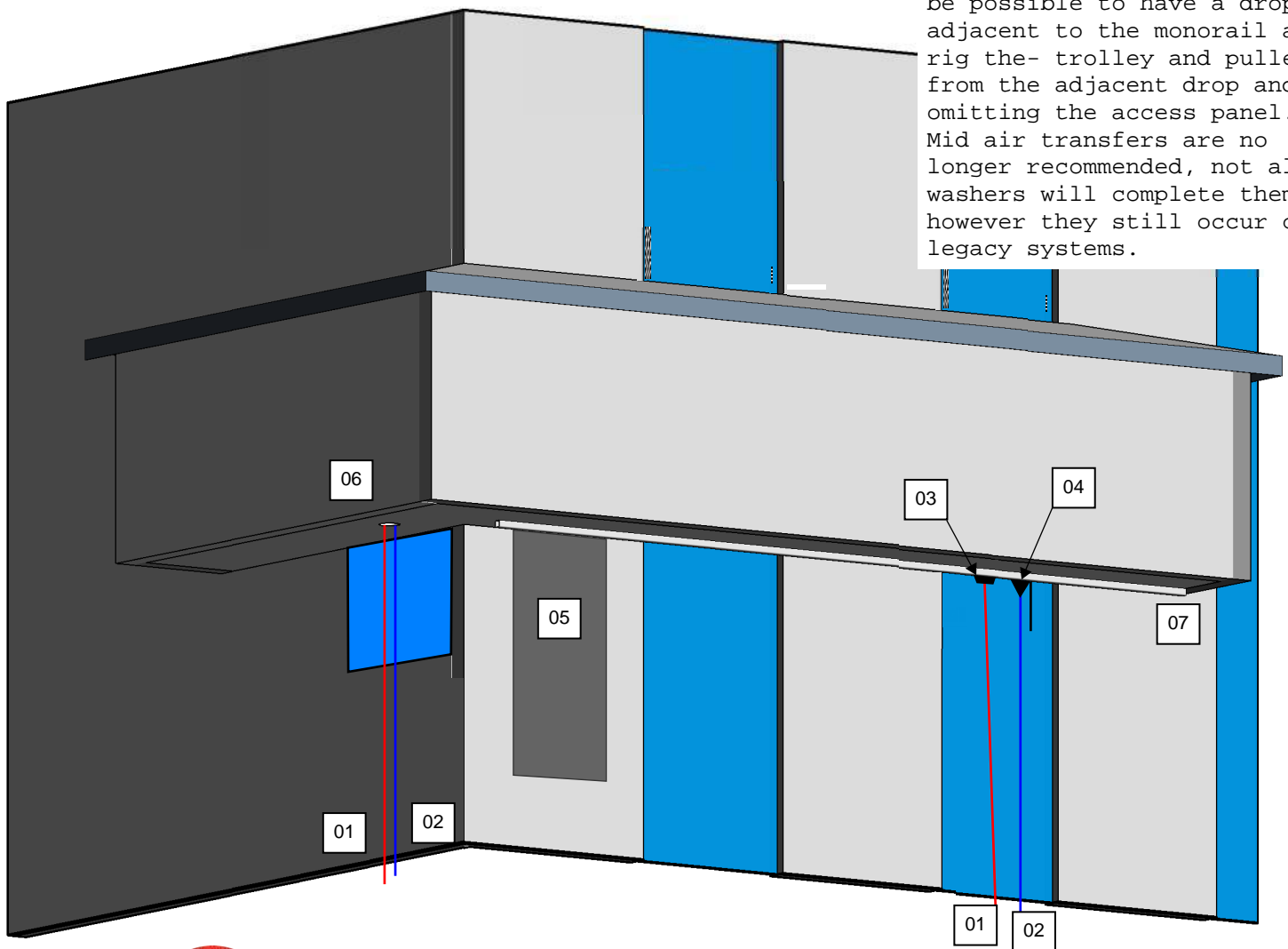

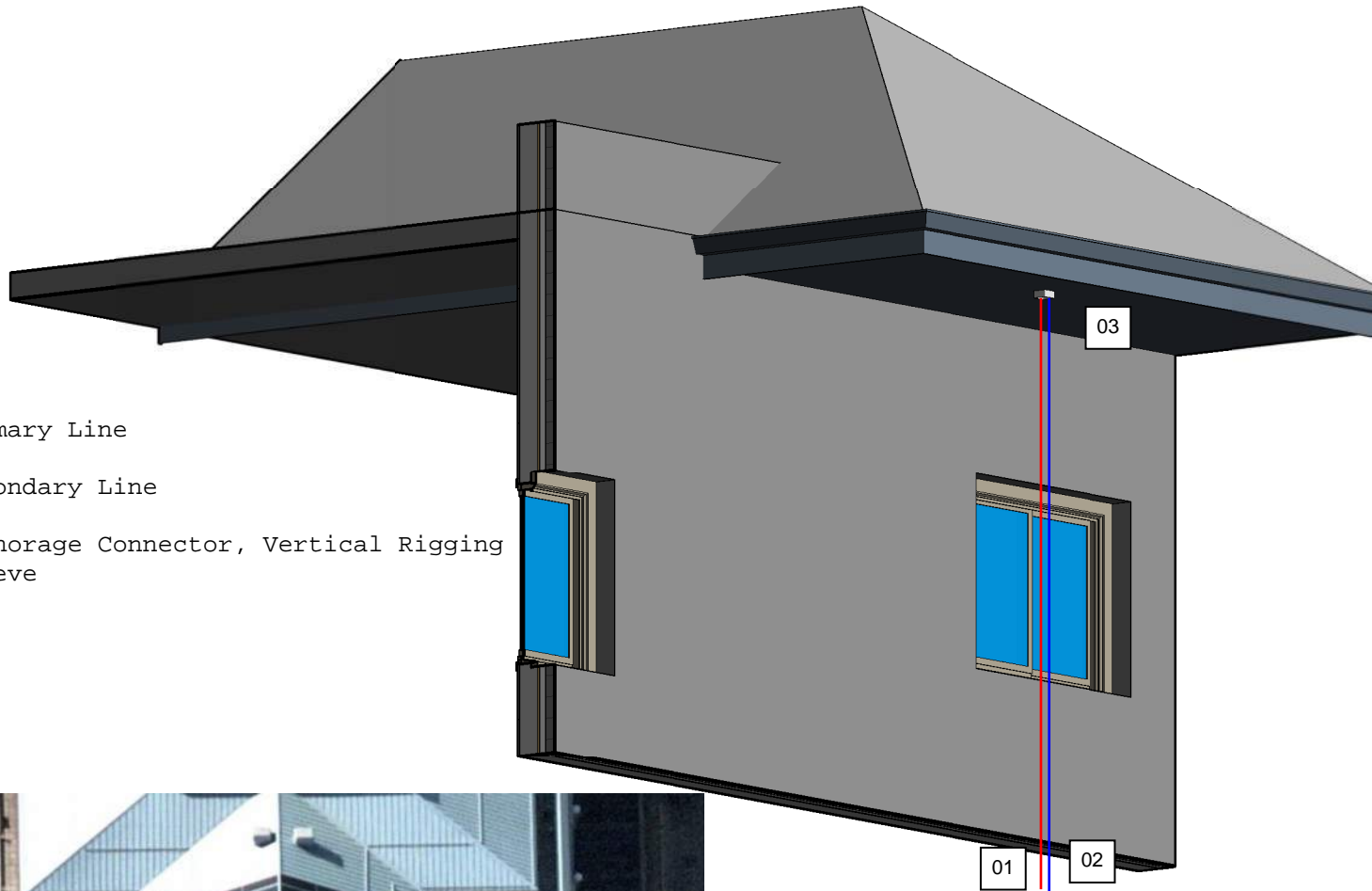

- 01 Primary Line
- 02 Secondary Line
- 03 Anchorage Connector, Vertical Rigging Sleeve

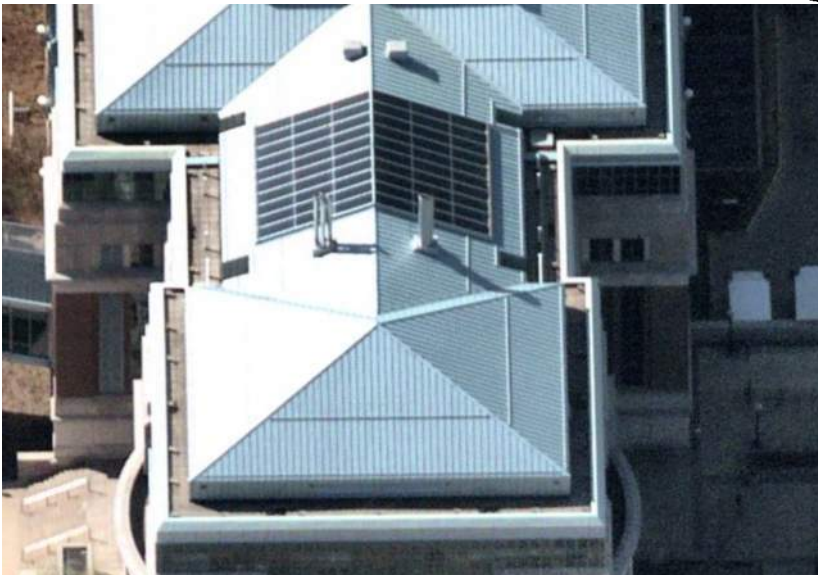

SLOPED ROOF WITH WALKWAY ALLOWING STANDARD EQUIPMENT

Typically mid and high rise sloped roofs have a flat area adjacent to a parapet wall to allow for standard suspended maintenance. In some cases the sloped roof runs to the edge causing vertical rigging sleeves to be needed (access is typically through an attic area).

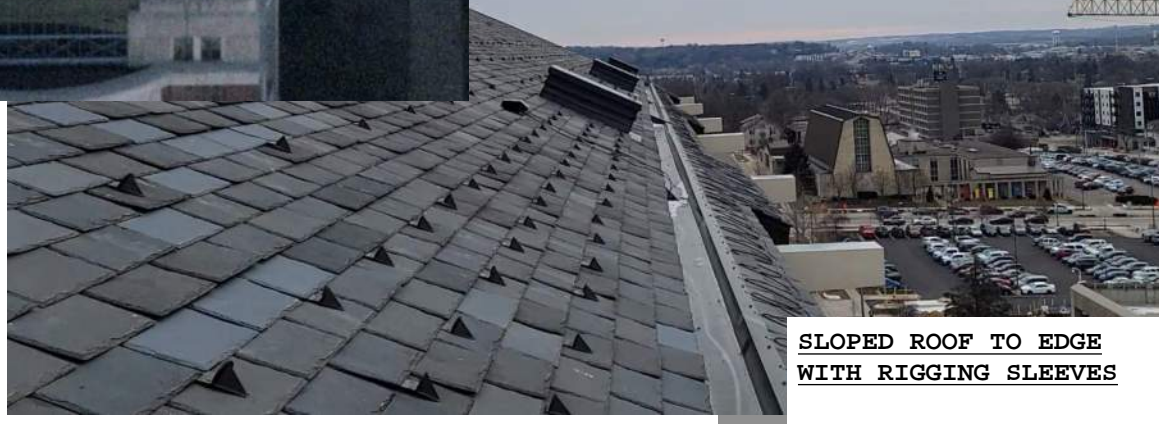

SLOPED ROOF TO EDGE WITH RIGGING SLEEVES

- 01 Primary Line
- 02 Secondary Line
- 03 Down and Under Rigging Beam
- 04 Anchorage Connector

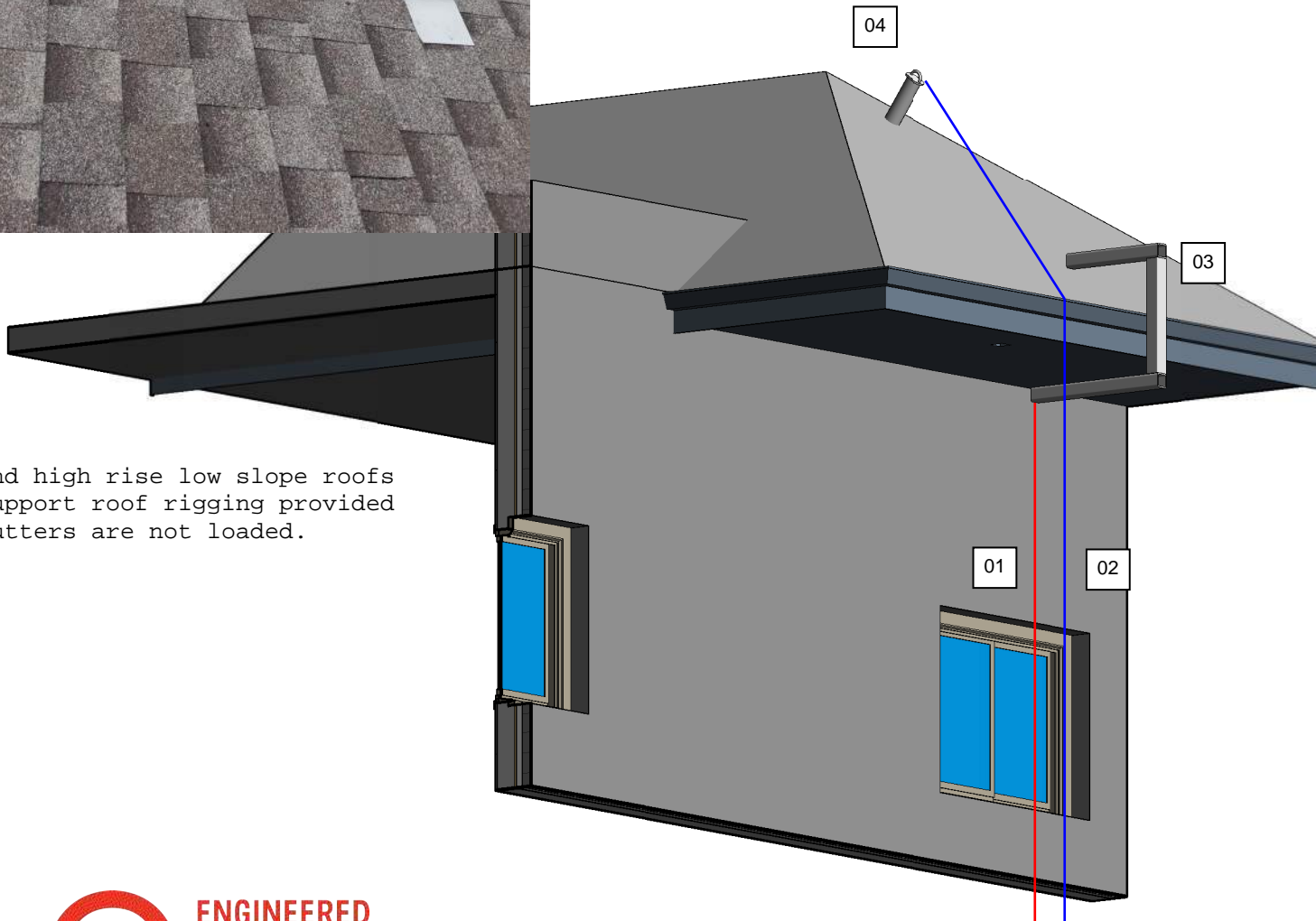

Mid and high rise low slope roofs can support roof rigging provided the gutters are not loaded.

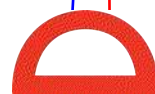
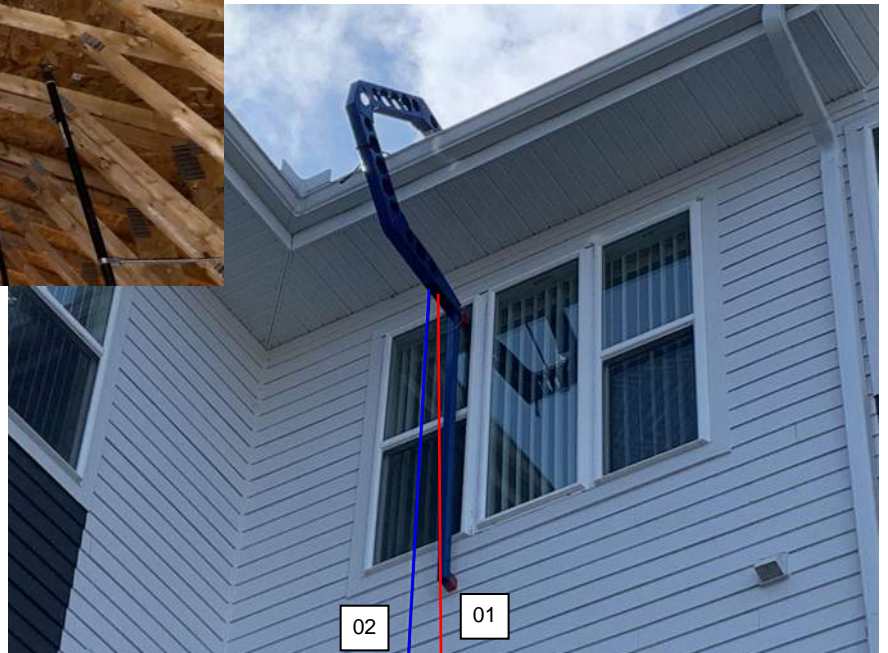
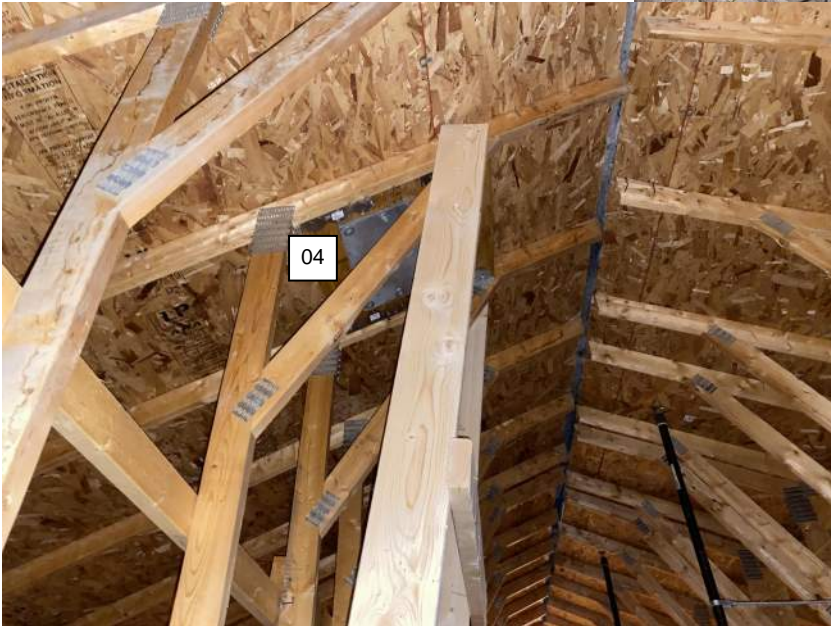
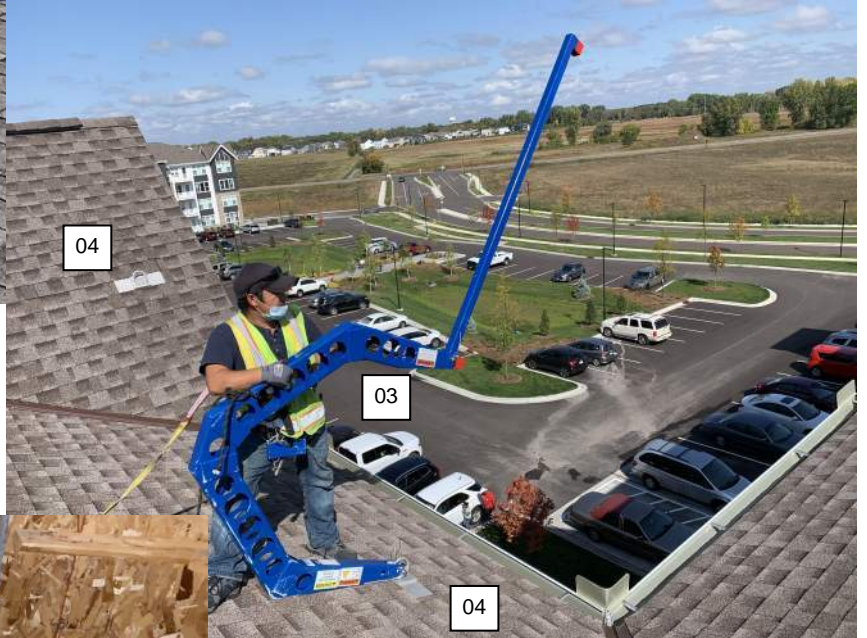

Window washers use rope descent to reach windows on mid and high rise buildings.

There are building features, such as sun screens and high level cantilevered balconies that make the process of going up the elevator and down the rope impossible, such as the one shown here where there is an architectural feature that prevents the user from descending down the rope.

In these cases, it is common to run the primary lines and secondary lines down to a hoist to travel up the rope.

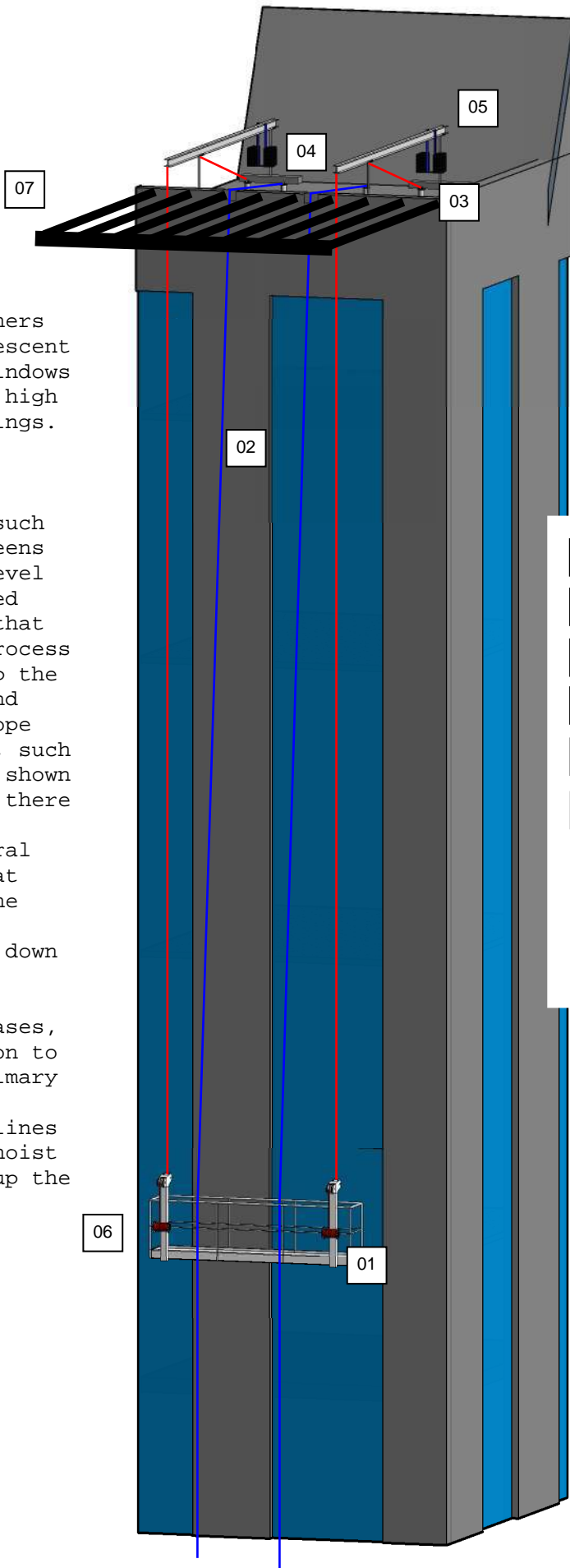

- 01 Primary Line (with Winder)
- 02 Secondary Line
- 03 Tieback Line
- 04 Pipe Anchorage Connector
- 05 Counterweighted Outrigger Beam
- 06 Ground Rigged Swingstage
- 07 Lines Passed through Obstruction

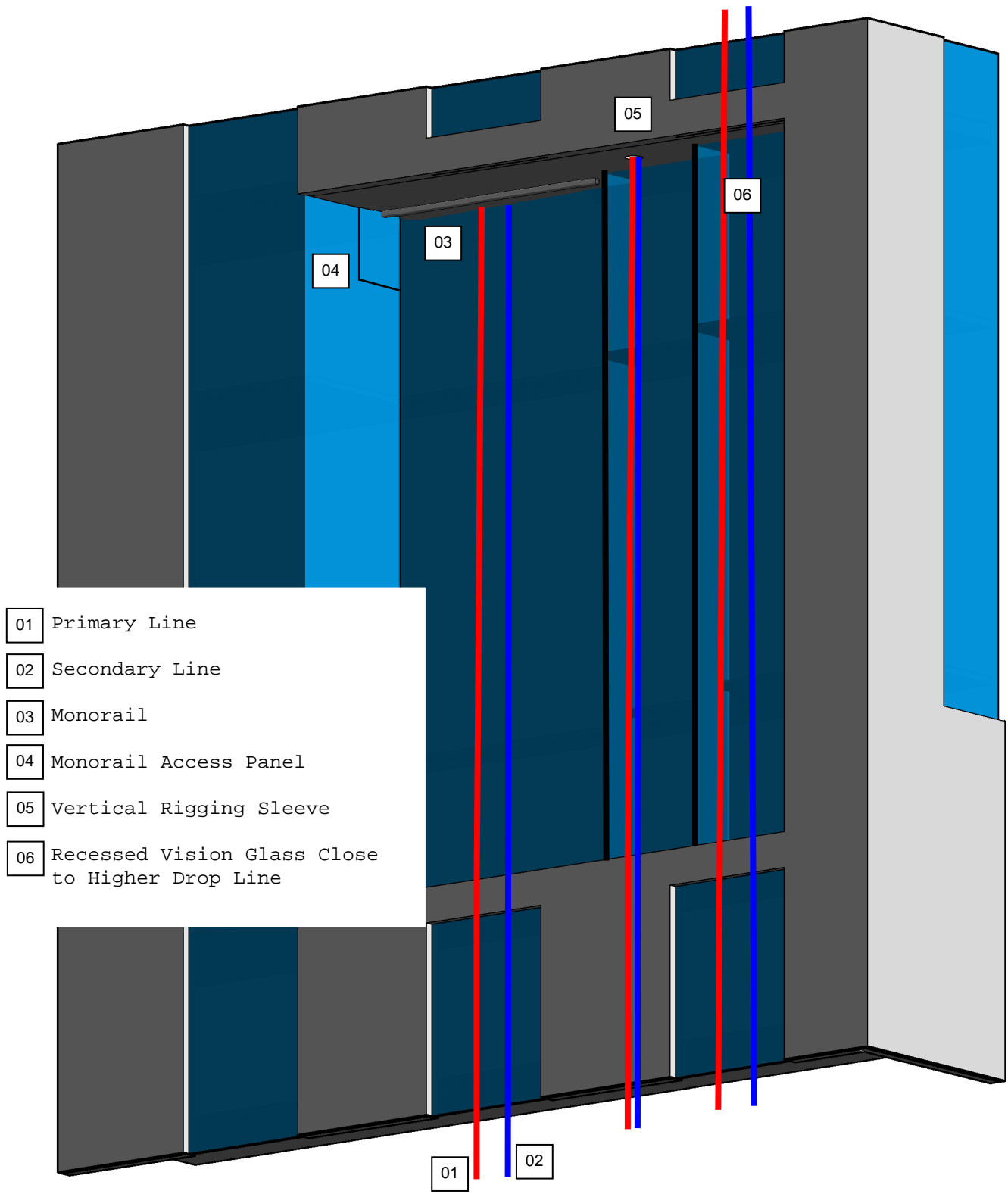



- 01 Primary Line
- 02 Secondary Line
- 03 Rigging Sleeve Anchorage Connector
- 04 Natural Anchorage Connector
- 05 Window Within 6' of Drop
- 06 Anchorage Connector, Pipe

If this window's vision glass is within 6' of the primary line, then the washer could reach over, if it was more than 6' over then a rigging sleeve would need to be added.

Lines passed through an obstruction require space to allow personnel to pass through.

Lines passed over an obstruction require that the user can reach the item to be serviced with the line farther away from the building facade.

Entrances require barricades (no one is allowed below suspended maintenance equipment in use)

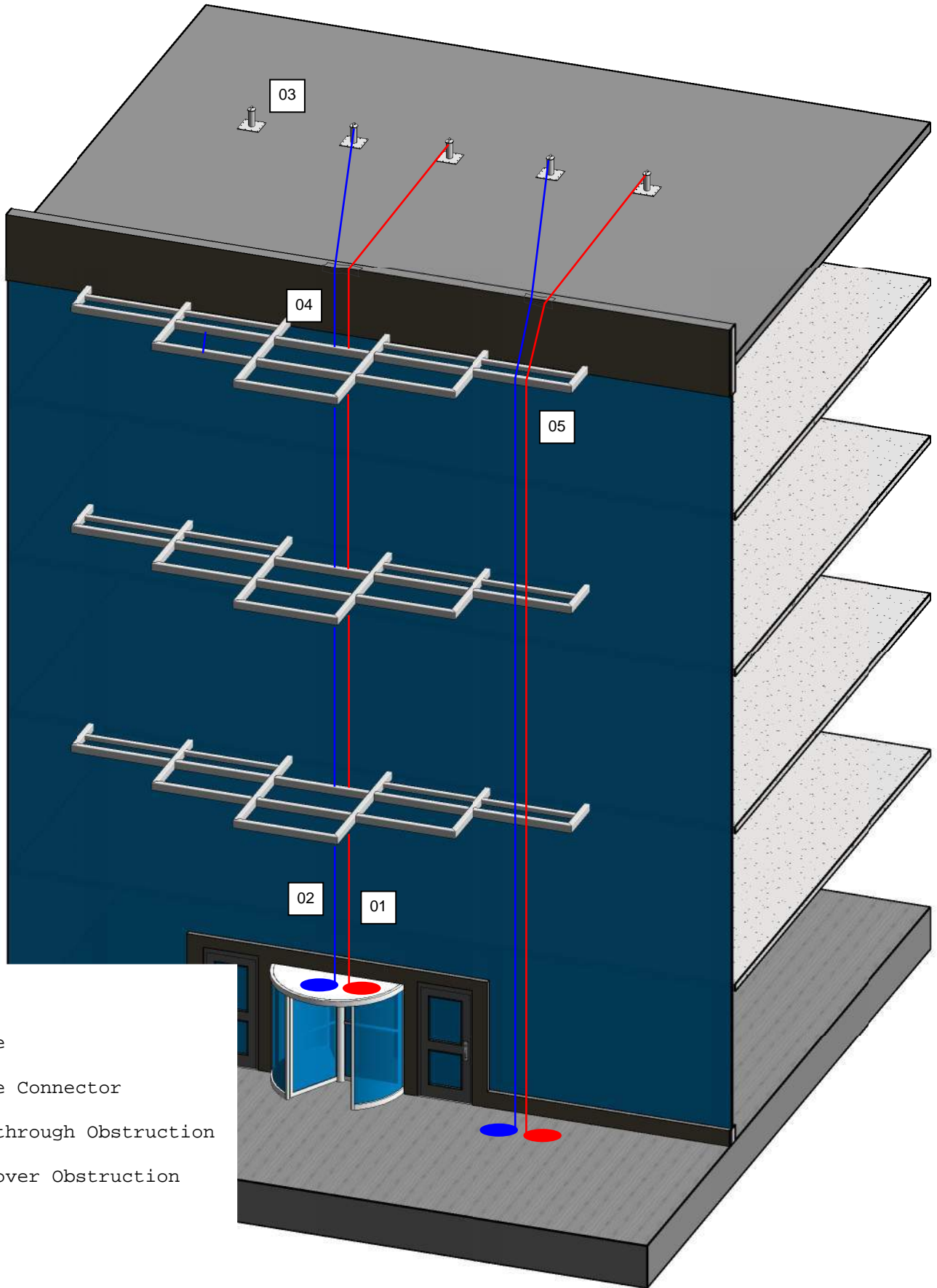

- 01 Primary Line
- 02 Secondary Line
- 03 Pipe Anchorage Connector
- 04 Lines Passed through Obstruction
- 05 Lines Passed over Obstruction



- 01 Primary Line
- 02 Secondary Line
- 03 Anchorage Connector
- 04 Counterweight Beam on Scaffold
- 05 Rigging Sleeve Anchorage Connector, In Use
- 06 Rigging Sleeve Anchorage Connector, Stowed
- 07 Catwalk

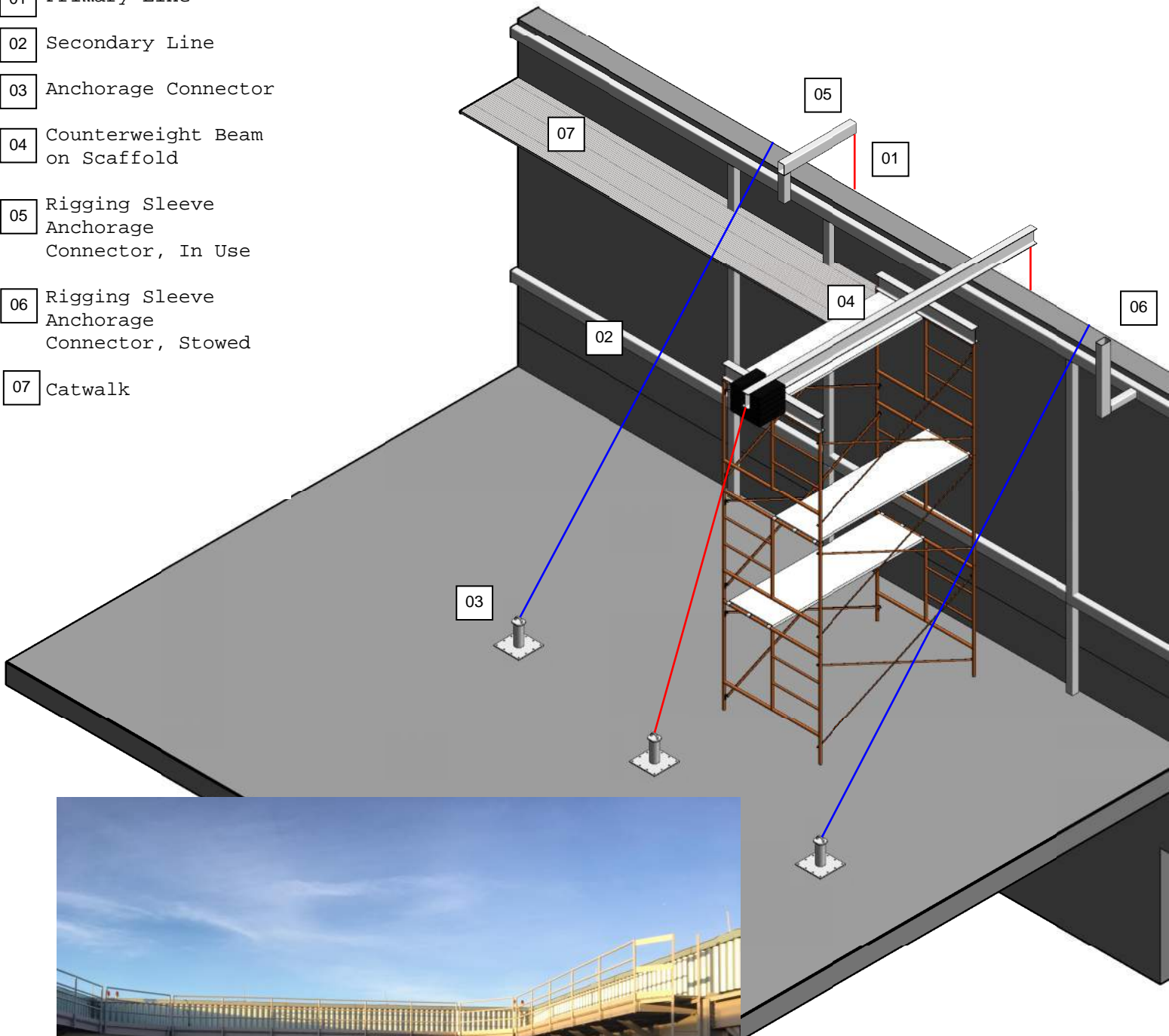

ACCESS CATWALK EXAMPLE

- 01 Primary Line
- 02 Secondary Line
- 03 Anchorage Connector
- 04 Erected Davit Arm
- 05 Davit Arm, Stowed
- 06 Catwalk

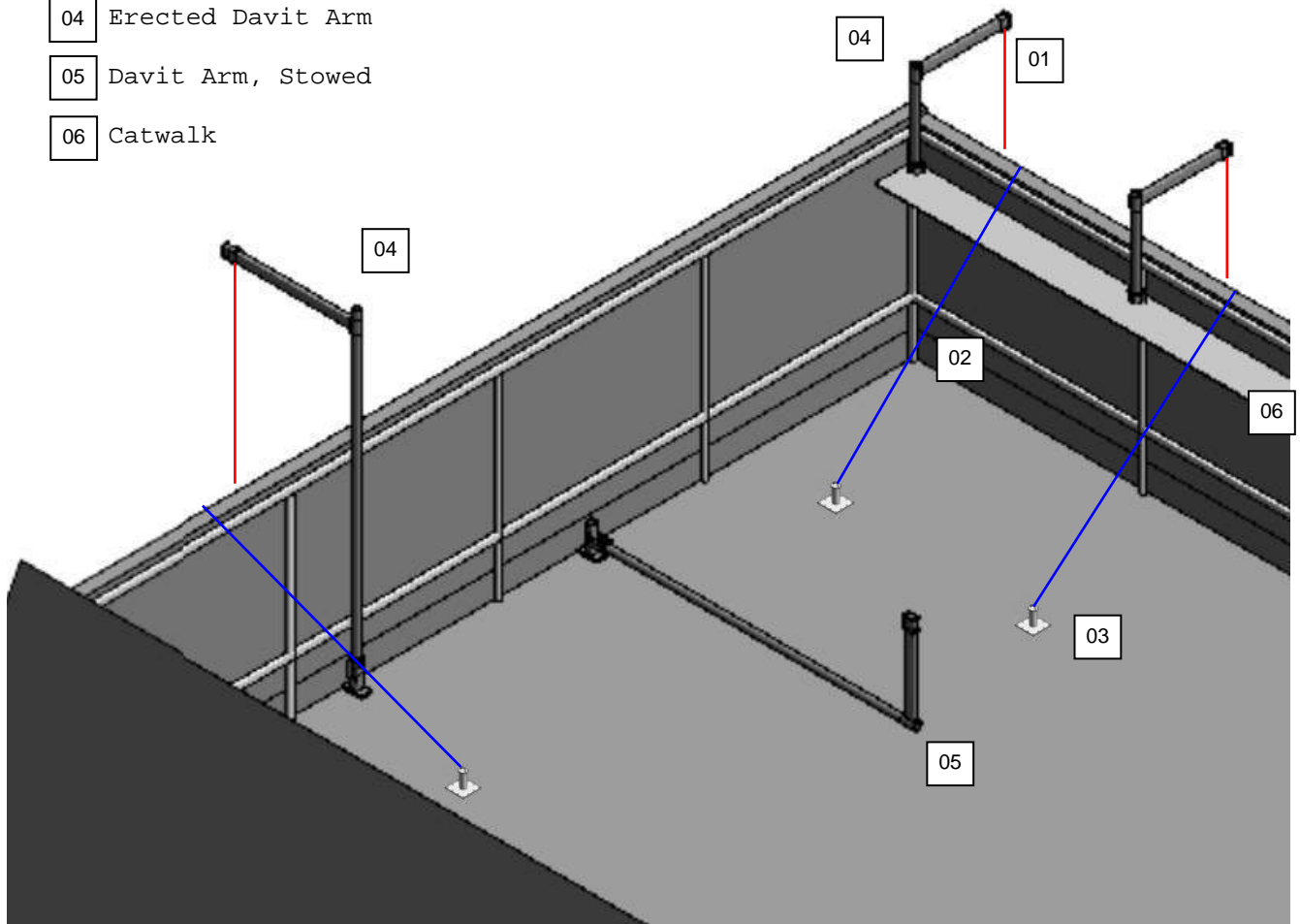



**ENGINEERED
SUPPLY®**

EQUIPMENT MANUAL

SUSPENDED MAINTENANCE ANCHORAGE CONNECTORS

SECTION FOUR

Testing and Documentation

Engineered Supply provides testing and subcontracted certification. This section includes information for our standard testing program as well as an initial log book and annual inspection forms.

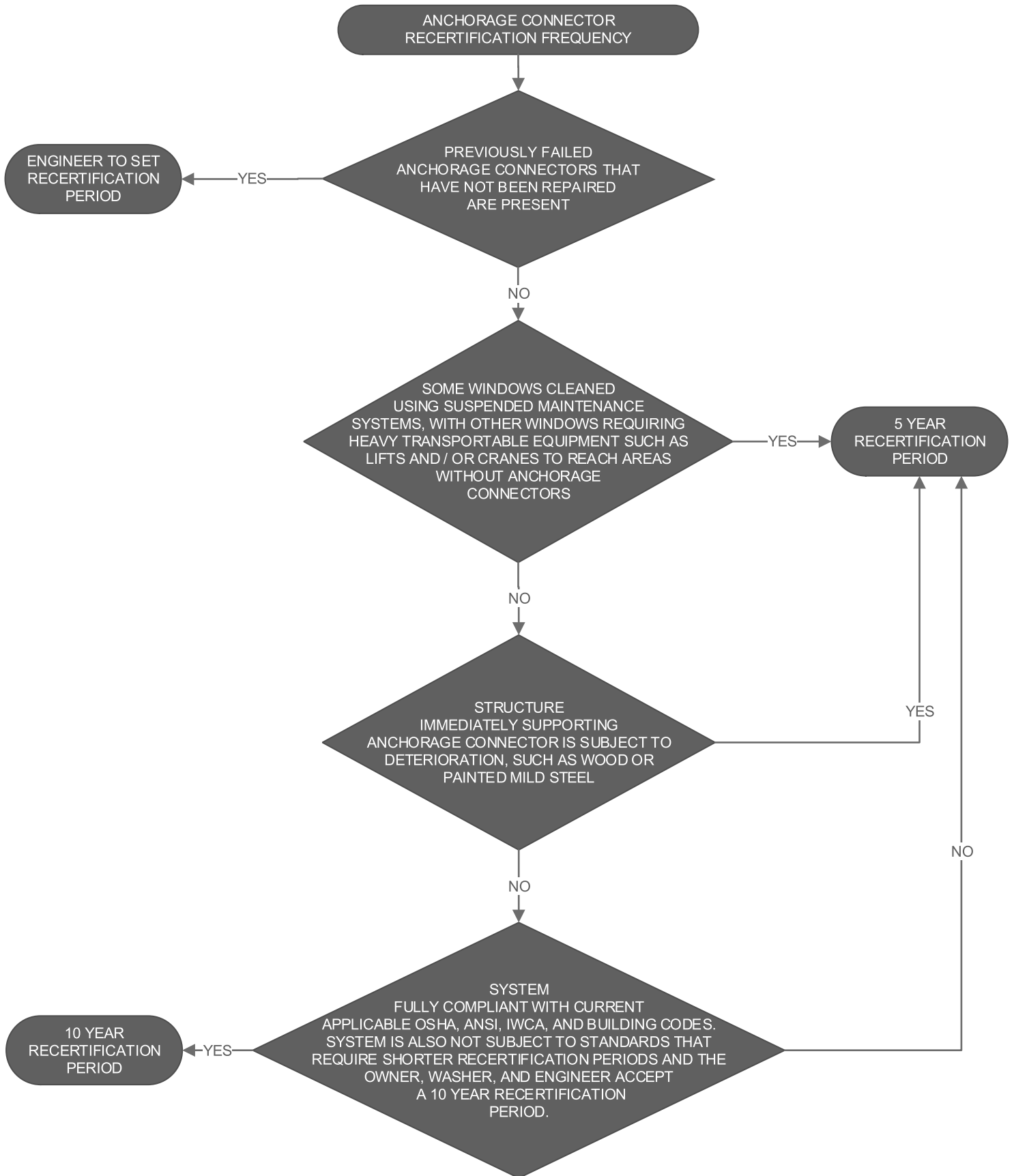

TESTING AND DOCUMENTATION

Anchorage connectors not rated to ANSI Z359.18-T, secondary, and primary structure shall be analyzed to determine the Design Strength is greater than the applied loads, as well as inspected and sample tested as shown to verify proper installation.

Load testing procedures to be in accordance to manufacturer recommendations. Alternate load testing procedures may reduce the Minimum Breaking Strength and / or void the applicable warranty and insurance, and is prohibited.

Testing anchorage connector installations without previous analysis is prohibited.

Judging the underlying condition by the visible condition is permitted within the confines of this standard.

Performing calculations on representative members judged typical is allowed within the confines of this standard.

The field verification test equipment is not required to control the rate of load application and the duration of load applied.

All testing equipment shall be kept in good condition, initially calibrated, and when applicable re-calibrated at a period not to exceed 1 year using methods satisfactory to the project's Professional Engineer.

If any anchorage connector fails, the testing shall immediately stop and the anchorage connector shall be fully exposed for the professional engineer to determine the cause and remedy. After remediation, 100% of similar anchorage connectors on that project shall be tested.

Inspection and testing shall not be completed by the same personnel that installed the anchorage connector. The installing company is permitted to also inspect and test provided there is no conflict of interest (a conflict of interest could be the testing personnel reporting directly to the same individual that the installation personnel directly report to). The testing personnel shall be Agents of the Professional Engineer or third party working directly for the Owner.

TESTING AND DOCUMENTATION

Field load testing may be completed with load applied at the base of the hoop, if this is in accordance with the manufacturer's recommendations.

Anchorage connectors shall be tested in the direction of use.

If one anchorage connector is rated for use in any direction, the anchor shall be tested in the direction of use that is judged to produce the largest stress.

In the case of multiple anchorage connectors which are used in multiple directions it is acceptable to test them in a convenient direction provided the anchorage connectors are tested at least once in each direction shown for use in the log book.

The Testing Company shall acknowledge there is risk of damage during field load testing, and that when the load testing is completed in accordance with industry standards, any associated repairs shall be completed by the Owner.

Testing of existing systems may require removal and replacement of some existing anchorage connectors. During a recertification process, if existing anchorage connector layouts comply with OSHA and other applicable legislative minimums for use, but do not fully comply with this and other applicable industry standards, the Log Book shall fully detail the shortcomings, any areas not accessible per legislative minimums, and provide alternate methods of access such as transportable lifts and / or cranes if reasonable. The Owner shall be provided with a plan in sufficient detail to allow budgetary pricing for a compliant system to be installed no later than the next significant re-roofing project.

If natural anchors are used, the exact model of transportable anchorage connector shall be specified in the log book.

New installations shall not allow two lines to be attached to the same hoop of one anchorage connector.

If no inspections are completed before connections are covered by finishes, the Professional Engineer may increase the verification testing requirements.

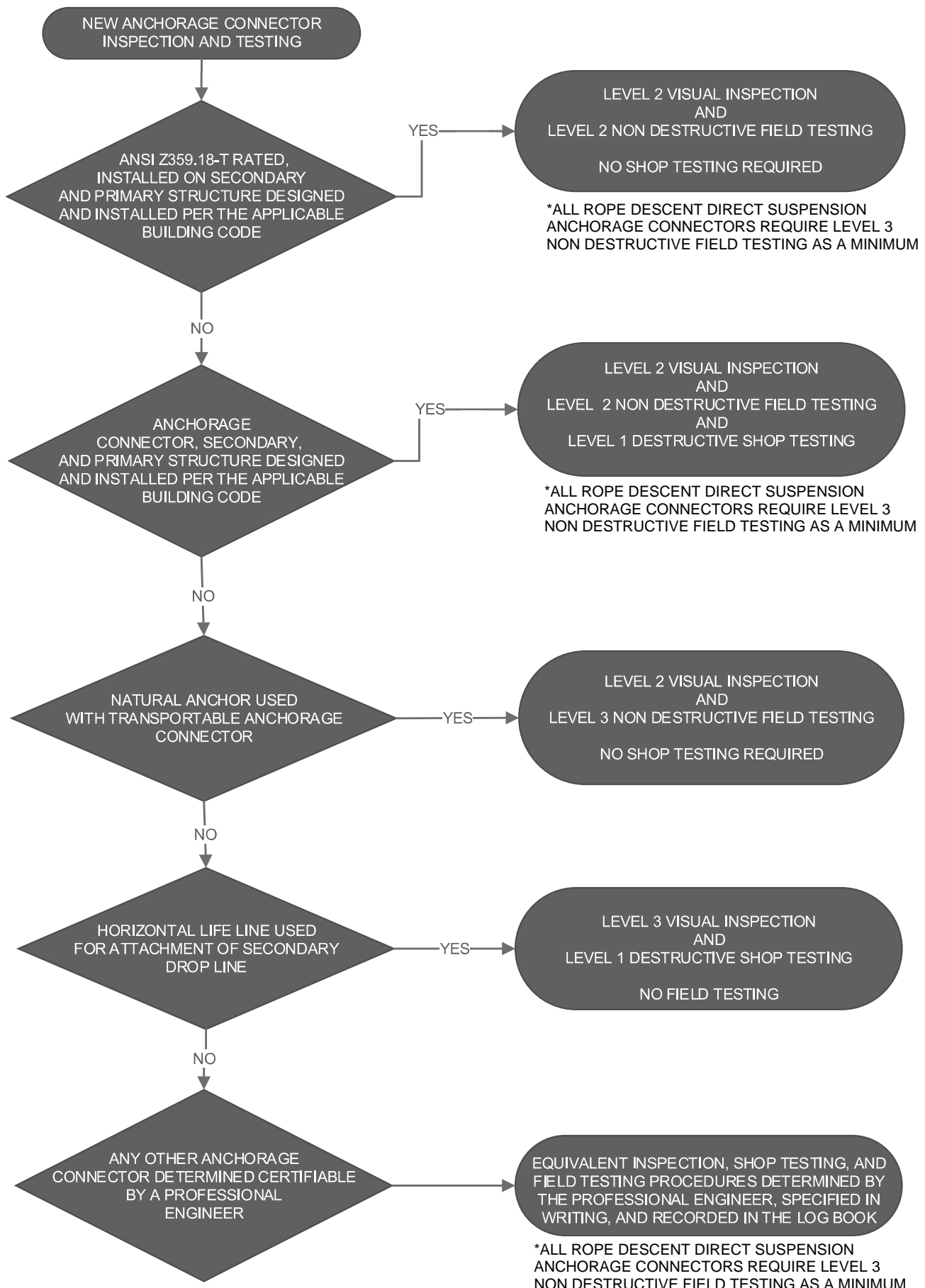

TESTING AND DOCUMENTATION

VERIFICATION TESTING

Level 1 Nondestructive Field Testing: 200% of the rated load (two times the working live load) load test on a minimum of 3 randomly selected anchorage connectors in direction of use with no loosening nor permanent deformation nor building envelope degradation. Verification test load shall not exceed one half the minimum qualification tested breaking strength or calculated nominal capacity. Verification test load shall not exceed the serviceability limits of the primary structure. If there are less than 3 anchorage connectors, it is acceptable to test 100% of the anchorage connectors.

Level 2 Nondestructive Field Testing is defined as the same as level 1 except at a rate of 33% of the anchorage connectors

Level 3 Nondestructive Field Testing: the same as level 1 except at a rate of 100% of the anchorage connectors

Existing anchorage connectors with two lines attached to one Eye may be tested with one attached line at 200% of the rated summation of the line loads (four times the working live load of one attached line) field load test on 100% of anchorage connectors in direction of use with no loosening nor permanent deformation nor building envelope degradation. Verification test load shall not exceed one half the minimum qualification tested breaking strength or calculated nominal capacity. Verification test Load shall not exceed the serviceability limits of the primary structure. No new anchorage connectors shall be designed for two lines going to one Eye.

Verification overload testing of portable and transportable equipment which can be fully inspected such as monorail trolleys, davit arms, outrigger beams, and similar is only required as a proof test when the equipment is first built and when the equipment is repaired or refurbished. Any overload testing that must be done after repairs and refurbishments of this equipment can only be performed with the manufacturer's written permission and according to the manufacturer's guidelines.

TESTING AND DOCUMENTATION

QUALIFICATION TESTING

Level 1 Destructive Shop Qualification Testing: a random sample of (1) anchorage connector of each type shop tested to the equivalent requirements of Serviceability Strength Test, Static Strength Test, Dynamic Strength Test, and Residual Dynamic Strength Test of ANSI Z359.18-T.

INSPECTION

Level 1 Visual Inspection: inspection of the visible portions of the anchorage connector, portions of the anchorage connector may be hidden by finishes, using sounding to identify potentially loose anchorage connectors. Condition of the exposed portions are used as an indication of underlying materials.

Level 2 Visual Inspection: intermittent inspection during the installation process and review of the final system by the professional engineer or their agent

Level 3 Visual Inspection: continuous inspection during the installation process and review of the final product by the professional engineer or their agent

Level 4 Visual Inspection: Level 1 Visual inspection and selecting one random anchorage connector of each type to expose the anchorage connector, and its attachments to the secondary structure.

During re-roof certifications, the Professional Engineer or their Agent shall observe all anchorage connectors, primary, and secondary structure that is exposed. It is acceptable to observe one anchorage type, and have the Contractor provide photographs for remote view for the remainder.

Only a Professional Engineer or their Agent may remove red tags from equipment.

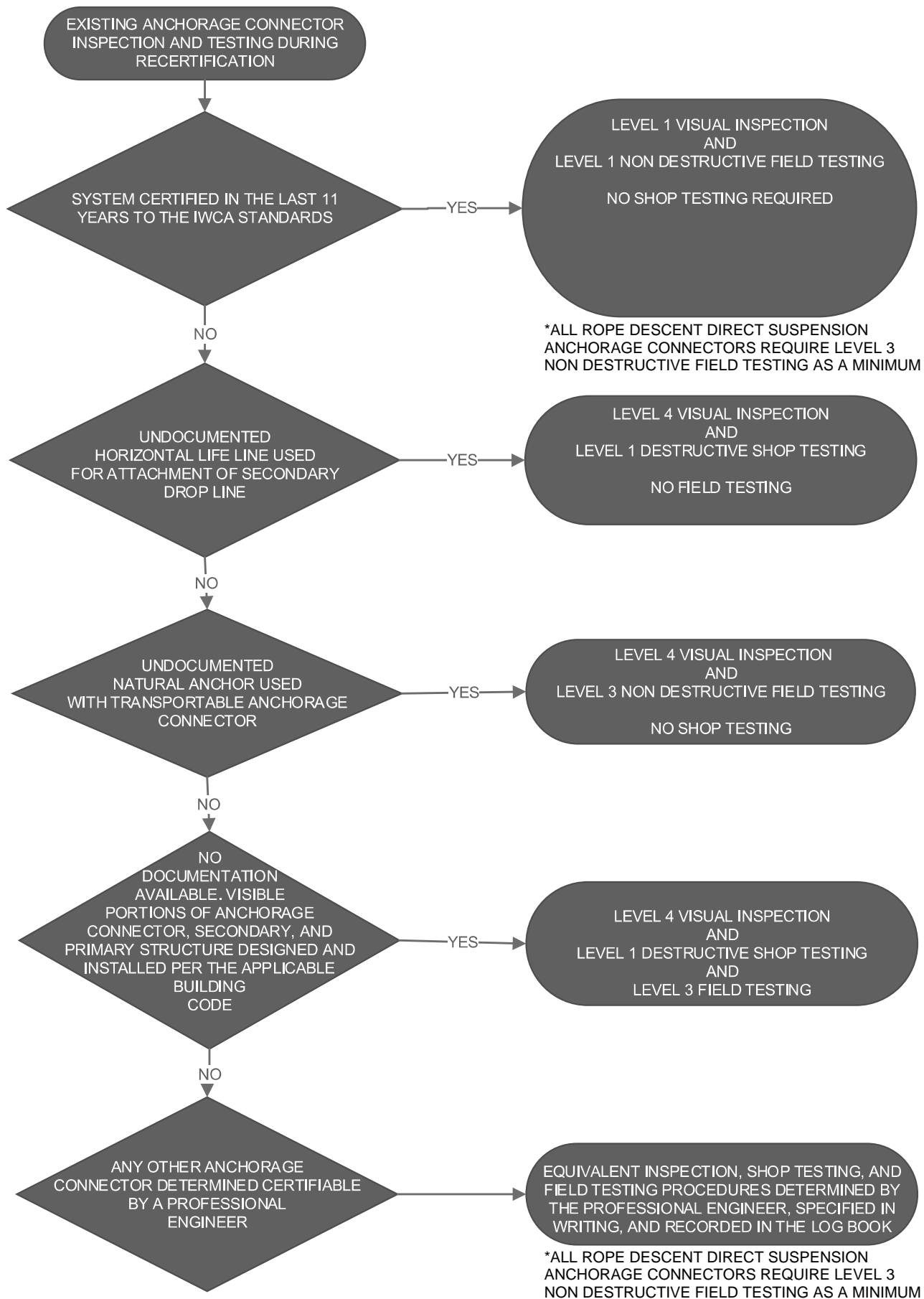

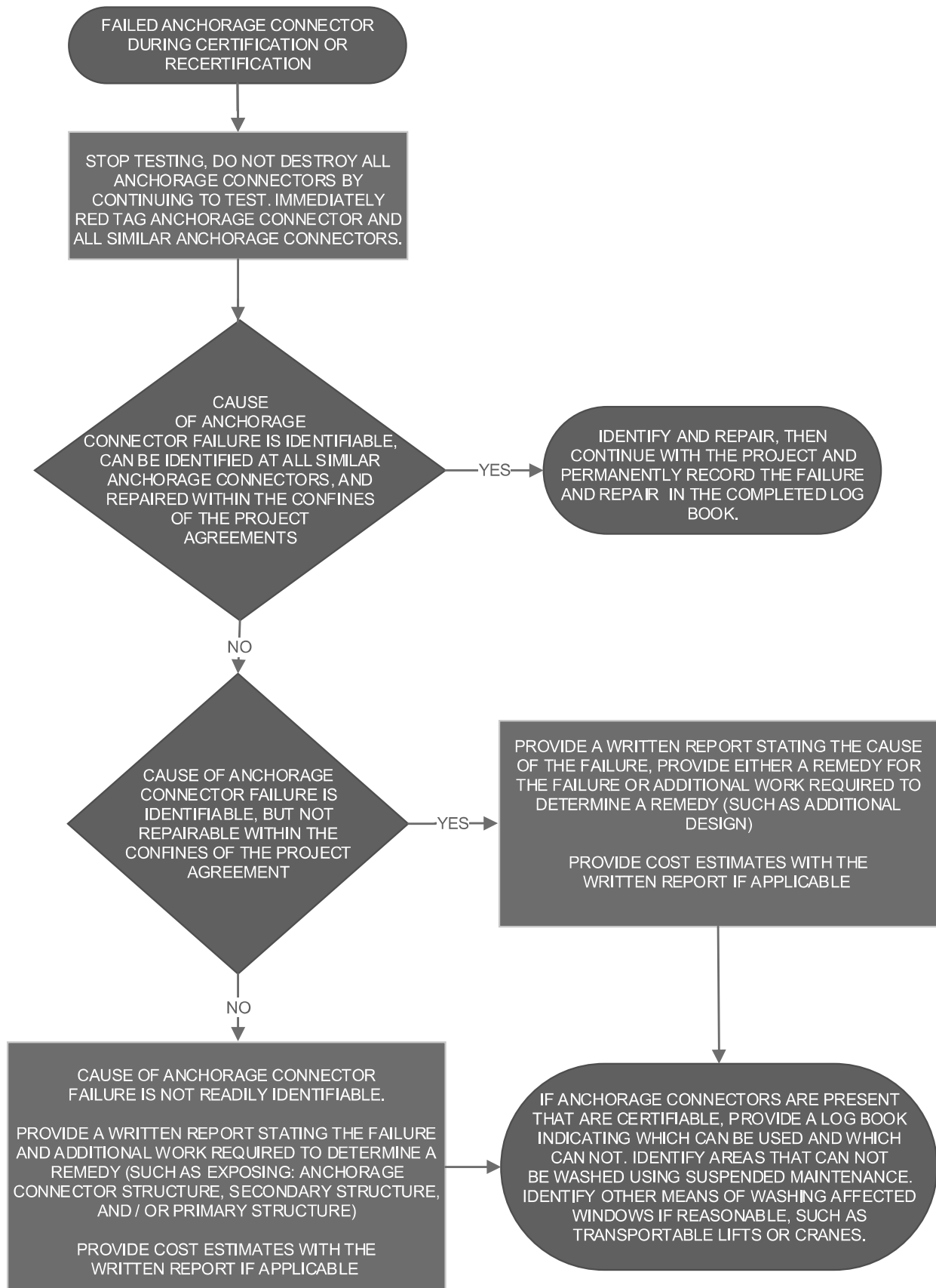



UNDERSIZED HOOP, BENT DURING TYPICAL SERVICE LOADING (CHAIR USE) (ALSO MISSING VENT PLUG)



MISSING VENT PLUG (COMMON ISSUE)

FINISHES REMOVED DUE TO SURFACE RUST STAINING AND NO HOT DIP FINISH



CORROSION THROUGH METAL (NOTE THE SHINY GRINDER MARK ON NON CORRODED METAL AND THE DULL FINISH AT THE GROUND CONNECTION, THIS ANCHOR BROKE OFF WITH A LIGHT SIDEWAYS HAND PULL)

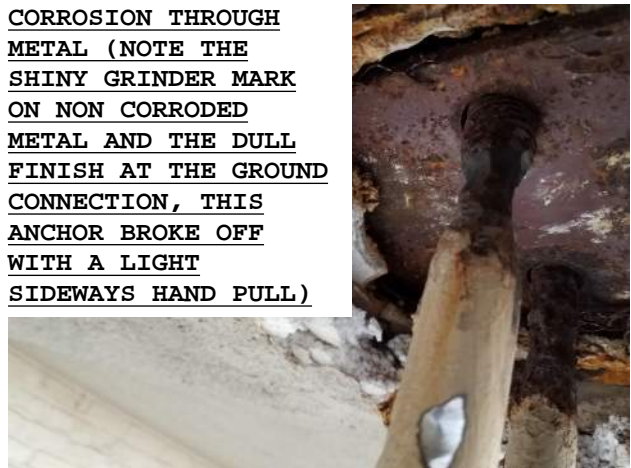

COLD TEMPERATURE EMBRITTLEMENT FAILURE (LABORATORY TEST)

PASS	PASS W/ LIMITATIONS	SYSTEM FAIL
-------------	----------------------------	--------------------

Notes (summary of limitations or summary reason for fail required if selected)

Annual Anchorage Connector Inspection Report – 2024

Client Billing: **Client Name**
 Client Contact
 Address 1
 Address 2

Date: ____/____/____

Project : **Building Name**
 Address 1
 Address 2

Project #: 24xxx.00

- We visited the site on ____/____/20____ to review and inspect the roof anchorage connections. This completed inspection is intended to identify potential indicators of deterioration or deficiency by visual observation and testing as determined necessary in accordance with the IWCA I14.1 2001.
- Reviewed and signed off on the Log Books for the required inspection. (where applicable)
- This Letter of Compliance finds the system is in compliance with the applicable codes and standards in force at the time of this letter report, and is ready for use as described below.
- We understand the anchorage systems were initially tested with a load test. Roof anchorage systems on this building must be re-tested and re-certified within **5** years under direct supervision of a licensed engineer. Re-testing and System Recertification is to occur by MM / 20YY

The following items and conditions were visually inspected and/or sounded using a hammer.

Typical designs for anchorage connectors (Roof Anchorage, Davit, Horizontal Life Line (HLL), and Monorail systems) are composed of one or more of the the following components. Not all structures employ the following systems in which case a 'Yes' or 'N/A' will be indicated, for those systems which apply.

Inspection Items Covered

Roof Anchorages Yes _____ N/A _____

- | | | | |
|---|---|---|----------------------|
| 1. Has the Roof Anchorage / Davit System / HLL / Mono Rail system been Inspected at annual intervals: | Y | N | |
| a) Last Roof Anchorage / Davit System / HLL / Mono Rail system Certification date: ____/____/____ (refer to ANSI / IWCA I14.1 2001 for certification requirements) | | | |
| b) Last Roof Anchorage / Davit System / HLL / Mono Rail system Inspection date: ____/____/____ (refer to ANSI / IWCA I14.1 2001 for inspection requirements) | | | - Locations - |
| c) Was a Log Book on site to be filled out and dated: | Y | N | _____ |
| 2. Is there corrosion / deterioration observed on the anchorages: | N | Y | _____ |

Engineered Supply

- | | | | |
|--|----------|----------|-------|
| 3. Are the manufacturing plugs tightly located in all locations: | Y | N | _____ |
| 4. Are there signs of loosening or corrosion when sounded: | N | Y | _____ |
| 5. Was permanent deformation of the roof anchors observed: | N | Y | _____ |
| 6. Are there signs of deterioration in the flashing materials: | N | Y | _____ |
| 7. Other_____ | | | |
| 8. Do existing roof anchorages meet requirements for usability: | Y | N | _____ |

Davit System Components Yes_____ N/A_____

Davit Arms:

- Locations -

- | | | | | |
|--|----------|----------|-----|-------|
| 1. Number of davit arms for this structure / system: | _____ | | | _____ |
| 2. Are warning labels and annual inspection stickers in place: | Y | N | | _____ |
| 3. Are cable lanyards and retaining pins in place and undamaged: | Y | N | | _____ |
| 4. Are davit masts /arms free of cracks and gouges: | Y | N | | _____ |
| 5. Do guide bearings rotate freely: | Y | N | N/A | _____ |
| 6. Are attachment eyes / rings tight in their locations: | Y | N | | _____ |
| 7. Are davit lifting brackets secured / functional: | Y | N | N/A | _____ |
| 8. Is the rotation brake fully functional: | Y | N | N/A | _____ |
| 9. Is the davit arm lifting winch fully functional: | Y | N | N/A | _____ |
| 10. Other_____ | | | | |
| 11. Do existing Davit Arms meet the requirements for usability: | Y | N | | _____ |

Davit Sockets: Yes_____ N/A_____

- | | | | | |
|--|----------|----------|-----|-------|
| 1. Number of davit sockets for this structure / system: | _____ | | | _____ |
| 2. Are warning labels and annual inspection stickers in place: | Y | N | | _____ |
| 3. Is there corrosion / deterioration observed on the davit sockets: | N | Y | | _____ |
| 4. Are the UHMW bearing surfaces free of cracks and oxidation: | Y | N | N/A | _____ |
| 5. Are the cable lanyards and retaining pins in place and undamaged: | Y | N | | _____ |
| 6. Other_____ | | | | |
| 7. Do existing Davit Sockets meet the requirements for usability: | Y | N | | _____ |

Davit Bases: Yes_____ N/A_____

- Locations -

Engineered Supply

- | | | | | |
|-----|---|---|---|-------|
| 1. | Is there corrosion / deterioration observed on the davit bases: | N | Y | _____ |
| 2. | Are there signs of loosening or corrosion when sounded: | N | Y | _____ |
| 3. | Are there signs of deterioration in the flashing materials: | N | Y | _____ |
| 4. | Other _____ | | | |
| 5.. | Do existing Davit Bases meet the requirements for usability: | Y | N | _____ |

Horizontal Life Line System (HLL) Yes _____ N/A _____

- Locations -

- | | | | | |
|----|--|-------|---|-------|
| 1. | Number of HLL systems for this structure / system: | _____ | | _____ |
| 2. | Are the cables tight and correctly routed through anchorage locations: | Y | N | _____ |
| 3. | Are the 'Fist Grip' clamps in place and properly torqued: | Y | N | _____ |
| 4. | Are the shock absorber and indicator mechanisms intact and not showing engagement: | Y | N | _____ |
| 5. | Do permanent 'pass-through' attachments navigate freely: | Y | N | _____ |
| 6. | Other _____ | | | |
| 7. | Do the HLL System(s) meet the requirements for usability: | Y | N | _____ |

Monorail Systems Yes _____ N/A _____

- Locations -

- | | | | | |
|----|--|-------|---|-------|
| 1. | Number of Mono Rail Systems for this structure: | _____ | | _____ |
| 2. | Was deformation observed in the rail system(s): | N | Y | _____ |
| 3. | Are all mounting bolts properly torqued: | Y | N | _____ |
| 4. | Do the trolleys move freely along the rail system(s): | Y | N | _____ |
| 5. | Does / do the rail brake(s) function properly: | Y | N | _____ |
| 6. | Other _____ | | | |
| 7. | Does the Mono Rail System(s) meet the requirements for usability: | Y | N | _____ |

Intermediate Stabilization Anchors (ISA) and Lanyards Yes _____ N/A _____

- Locations -

- | | | | | |
|----|---|---|---|-------|
| 1. | Are the anchorage points securely attached to the buildings facade: | Y | N | _____ |
| 2. | Are there any signs of deformation, breaking, or corrosion: | N | Y | _____ |
| 3. | Other _____ | | | |
| 4. | Do the ISA System(s) meet the requirements for usability: | Y | N | _____ |

The opinions and recommendations contained in this report are based on a limited observation and investigation of the noted building. No attempt was made to perform an exhaustive investigation of all conditions and every building

Engineered Supply

element. It is possible that conditions exist that cannot be discovered or judged as a result of this limited nature of investigation. The work provided in the preparation of the report concerns the structural system only and is not intended to address architectural, mechanical, electrical, plumbing systems, fire protection, or handicap accessibility. No attempt was made to remove finish materials or gain access to concealed areas. The condition of the finish material was judged to be a good indication of the apparent condition of the underlying materials.

In recognition of the relative risks, rewards and benefits of the project to both the Client and Engineered Supply, LLC, the risks have been allocated so that the Client agrees that, to the fullest extent permitted by law, ES's total liability to the Client, for any and all injuries, claims, losses, expenses, damages or claim expenses arising out of this agreement, from any cause or causes, shall not exceed the total of five times ES's received payment or one million dollars whichever is less. Such causes include, but are not limited to ES's negligence, errors, omissions, strict liability, breach of contract or breach of warranty.

Systems users to inspect all equipment prior to each use, including all visible attachment points, locks, and pins to ensure all equipment is in safe working order. All users shall be trained on proper use of the equipment, as well as knowing and complying with OSHA, ANSI and other pertinent life safety regulations. All equipment shall be annually inspected by a qualified person and also re-certified within **5** years under direct supervision of a licensed engineer. Before this type of system is used, a rescue plan must be in place in case of emergencies. The user of the system is typically responsible for providing this plan.

If you have any questions concerning the above please do not hesitate to contact us.

Sincerely,

Printed Name

Signature of Competent Qualified Inspector

ANCHORAGE CONNECTOR LOGBOOK

Building Name

Building Address 1

Building Address 2

**INSERT PHOTOGRAPH OF BUILDING FROM STREET, TYPICALLY A VIEW OF THE
ENTRANCE**

Prepared for:

Client Name

Client Address 1

Client Address 2

Prepared by:

Company Name

Company Address 1

Company Address 2

Contents

Scope and Purpose 3
Qualifications 4
Initial Testing 4
Limiting Conditions 6
Appendix A – Roof Anchor Inspection Locations 7
Appendix B – Inspection and Initial Testing Log 8
Appendix C – Retest Log 10
Appendix D – Maintenance Log 12
Appendix E – Annual Inspection Log 13

Scope and Purpose

This logbook provides anchorage information, proof of certification, and proof of inspection. It also establishes a maintenance record that includes a description of each maintenance activity, the date of the maintenance activity, and signature of the responsible party.

Rope Descent Anchorages

OSHA 29 CFR 1910.27(b)(1)(i) states: “Before any rope descent system is used, the building owner must inform the employer, in writing that the building owner has identified, tested, certified, and maintained each anchorage so it is capable of supporting at least 5,000 pounds (2,268 kg), in any direction, for each employee attached. The information must be based on an annual inspection by a qualified person and certification of each anchorage by a qualified person, as necessary, and at least every 10 years.”

Swing Stage Anchorages

OSHA 29 CFR 1910.66(c)(3) states: “Building owners of all installations, new and existing, shall inform the [Contractor] in writing that the installation has been inspected, tested, and maintained in compliance with the requirements of paragraphs (g)(*Inspection and tests*) and (h)(*Maintenance*) of this section and that all anchorages meet the requirements of 1910.140(c)(13)(*Anchorages*).”

OSHA 29 CFR 1910.66(g)(2)(iii) and (g)(3)(ii) state: “The building owner shall keep a certification record of each inspection and test required under paragraphs (g)(2)(*Periodic inspections and tests*) and (g)(3)(*Maintenance inspections and tests*) of this section. The certification record shall include the date of the inspection, the signature of the person who performed the inspection, and the number, or other identifier, of the building support structure and equipment which was inspected. This certification record shall be kept readily available for review by the Assistant Secretary of Labor or the Assistant Secretary’s representative and by the [Contractor].”

Fall Protection Anchorages

OSHA 29 CFR 1910.140(c)(13) states: “Anchorages [...] must be capable of supporting at least 5,000 pounds for each employee attached or design, installed, and used, under the supervision of a qualified person, as part of a complete personal fall protection system that maintains a safety factor of at least two.”

Additional work is required beyond the scope of this logbook such as (1) a written safety plan prepared by the window washer / building maintainer, (2) logbooks for transportable equipment, and (3) other requirements as deemed necessary by the Authority Having Jurisdiction.

Qualifications

Inspection Company Name has extensive experience in the inspection of all types of suspended access and fall protection systems, holds insurance specifically for the installation of anchorage connectors and has been involved in the industry for **XX** years.

Our experience includes systems installed in buildings constructed at the time of the subject building's original construction.

Inspector's Name has been involved in the industry for **XX** years, and holds a Certificate / Degree from **Institution Name**, see the Inspection Log for their approval.

Initial Testing

100% of the anchorage connectors were pull tested to 2,500 pounds tension force with no signs of permanent deformation or loosening using a **model of dynamometer and hoist type**.

All components of the horizontal lifeline system(s), where applicable, were inspected to verify proper installation, including 100% of the length of the cable, all cable connections, turn buckles, and Cable Fuse tension indicator/shock absorbers. Due to the sacrificial nature of the Cable Fuse tension indicator/shock absorber, a pull test of 2,500-pound tension force is not appropriate for this system and was not performed.

Refer to Photographs 1 and 2 for examples of this testing.

INSERT PHOTO HERE

Photograph 1: Cable winch and scale between two anchors.

INSERT PHOTO HERE

Photograph 2: Scale Showing 2500lbf load.

Limiting Conditions

Systems users to inspect all equipment prior to each use, including all visible attachment points, locks, and pins to ensure all equipment is in safe working order. All users shall be trained on proper use of the equipment, as well as knowing and complying with OSHA, ANSI and other pertinent life safety regulations. All equipment shall be annually inspected by a qualified person and re-certified within 5 years under direct supervision of a licensed engineer. Before this type of system is used, a rescue plan must be in place in case of emergencies. The user of the system is typically responsible for providing this plan.

The opinions and recommendations contained in this report are based on a limited observation and investigation of the noted building. No attempt was made to perform an exhaustive investigation of all conditions and every building element. It is possible that conditions exist that cannot be discovered or judged as a result of this limited nature of investigation. The work provided in the preparation of the report concerns the structural system only and is not intended to address architectural, mechanical, electrical, plumbing systems, fire protection, or handicap accessibility. No attempt was made to remove finish materials or gain access to concealed areas. The condition of the finish material was judged to be a good indication of the apparent condition of the underlying materials.

In recognition of the relative risks, rewards and benefits of the project to both the Client and Engineered Supply, LLC the risks have been allocated so that the Client agrees that, to the fullest extent permitted by law, Engineered Supply's total liability to the Client, for any and all injuries, claims, losses, expenses, damages or claim expenses arising out of this agreement, from any cause or causes, shall not exceed five times the amount received by Engineered Supply for this scope of work. Such causes, include, but are not limited to Engineered Supply LLC's negligence, errors, omissions, strict liability, breach of contract or breach of warranty.

Respectfully Submitted:

NAME AND SIGNATURE OF COMPETENT QUALIFIED PERSON

**PROFESSIONAL ENGINEER
CERTIFICATION HERE**

Appendix A – Roof Anchor Inspection Locations

Please see the attached record drawing for anchor locations.

INSERT ANCHORAGE CONNECTOR DRAWINGS AFTER THIS PAGE

Appendix E – Annual Inspection Log

Project Name: **Building Address** – Roof Anchor Testing

Anchor Locations: See Appendix A

Date Required	Date	Acceptable for Use? (yes or no)	Initials	Company	Notes
Month Year					
Month Year					
Month Year					
Month Year					
RECERT YEAR					



**ENGINEERED
SUPPLY®**

EQUIPMENT MANUAL

SUSPENDED MAINTENANCE ANCHORAGE CONNECTORS

SECTION FIVE

Common Data Sheets and Installation Details

Engineered Supply provides data sheets and installation details on request. This section includes some of our more common stocked products.

REVISIONS				
ZONE	REV	DESCRIPTION	DATE	APPROVED
-	2	ISSUED FOR USE (10 YEAR UPDATE)	11/12/2023	APG

GENERAL NOTES

The installation contractor is solely responsible for site safety. Site visits by Engineered Supply do not include review of the contractor's safety precautions.

Installation drawings documenting the base materials and anchor bolts shall be provided by others and shall be reviewed by an experienced licensed engineer for all tieback and rope descent systems, or by a competent qualified person for all fall protection systems.

BASE MATERIALS Base material shall be structural steel, precast concrete, cast in place concrete, solid grouted masonry block, solid wood blocking, or equal with written approval from Engineered Supply.

Base material shall be capable of supporting the loads shown in accordance with the current applicable codes for the project location.

ANCHOR BOLTS Anchor bolts shall be strictly per Engineered Supply's recommendations or reviewed by an experienced licensed engineer.

Anchor bolts shall consist of either 4-, 8-, or 12- 1/2"Ø 300 series stainless steel or hot dipped galvanized steel materials. Anchor bolt embedment varies based on pipe height, and shall be determined by the base material for the specific installation.

Anchoring systems shall be Hilti HY270 adhesive, Hilti HY200 adhesive, Hilti HDA Undercut, Hilti Kwik Bolt TZ, cast in place threaded rods with embedded double nuts and washer, lag bolts rated for structural use in buildings, through bolt or equal seismic rated anchor with written approval from Engineered Supply. Note: lag bolts not allowed in the state of CA for suspended maintenance use.

All anchors shall be installed in strict accordance with the anchor manufacturer's instruction.

100% of adhesive anchors require tensile pull test to a force equivalent to the test load. Anchor bolts shall have deformed thread nuts, or permanent thread locking chemical to prevent loosening. Anchor fasteners shall be torqued with a calibrated wrench in accordance to the anchor manufacturer's literature.

INSPECTION AND TRAINING All fall protection and suspended maintenance equipment shall be selected or designed by others.

Usage shall comply with the current version of the ANSI IWCA I14.1. Systems users to inspect all equipment prior to each use, including all visible attachment points, locks, and pins to ensure all equipment is in safe working order. All users shall be trained on proper use of the equipment, as well as knowing and complying with OSHA, ANSI and other pertinent life safety regulations.

Equipment for rope descent and tie back use shall be initially load tested under the direction of a licensed engineer, annually inspected by a competent qualified person, and also re-certified within 5 years under direct supervision of an experienced licensed engineer.

BUILDING ENVELOPE Installation and materials surrounding the anchor shall be designed by others in compliance with the applicable manufacturer's instructions and shall maintain the existing building warrantee as applicable.

THIS ANCHORAGE CONNECTOR SHOP TESTS ELASTICALLY AT 5,000 POUNDS FORCE APPLIED AT THE TOP OF HOOP, PERPENDICULAR TO HOOP.

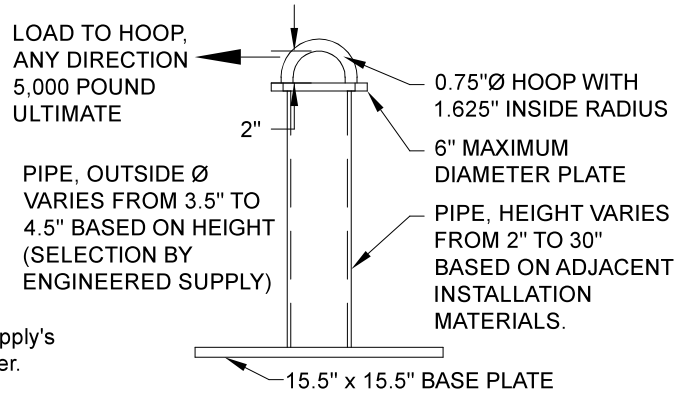

UNIVERSAL PIPE ANCHOR ASSEMBLY

STOCKED IN 14", 18", AND 24" PIPE HEIGHTS, THESE STOCKED PRODUCTS ARE COMPLIANT WITH ANSI Z359.18-T, IBC, AISC, AWS, IWCA I-14.1, OSHA, AND CAL-OSHA.

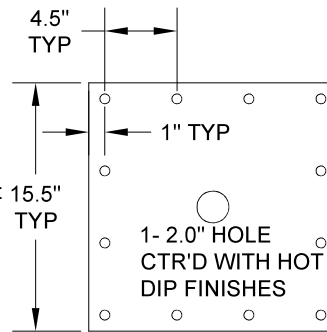

BASE PLATE HOLE PATTERN

PLATE THICKNESS VARIES FROM 0.375" TO 1" THICK BASED ON PIPE HEIGHT AND BASE PLATE MATERIAL (SELECTION BY ENGINEERED SUPPLY)

UNIVERSAL PIPE ANCHOR HXX"
 MODEL _____ PIPE HEIGHT _____
 OPTION TO ADD 1/4", 1/2", OR 1" THERMAL INSULATION (IN INCHES)

ORDERING INFORMATION

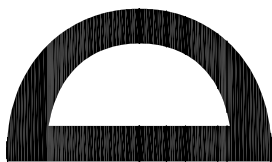

ENGINEERED SUPPLY

201 2ND AVE SOUTH
 BAYPORT, MINNESOTA 55003

651-439-0932
 ENGINEEREDSUPPLY.COM

STRONGTOP®
 Permanent Suspended Maintenance

ES P/N 901002-101

DATA SHEET, UNIVERSAL PIPE ANCHOR, 5000 LB, 12- HOLE

SIZE	PATENT NO.	DWG NO.
8.5x11	D772040	901002-101

THIS DRAWING AND THE DESIGN SHOWN IS THE SOLE PROPERTY OF ENGINEERED SUPPLY.

SCALE 1" = 1'-0" SHEET 1 of 1

REVISIONS				
ZONE	REV	DESCRIPTION	DATE	APPROVED
-	2	ISSUED FOR USE (10 YEAR UPDATE)	11/14/2023	APG

GENERAL NOTES

The installation contractor is solely responsible for site safety. Site visits by Engineered Supply do not include review of the contractor's safety precautions. Installation drawings documenting the base materials and welds shall be provided by others and shall be reviewed by an experienced licensed engineer for all tieback and rope descent systems, or by a competent qualified person for all fall protection systems.

THIS ANCHORAGE CONNECTOR SHOP TESTS ELASTICALLY AT 5,000 POUNDS FORCE APPLIED AT THE TOP OF HOOP, PERPENDICULAR TO HOOP.

BASE MATERIALS

Base material shall be mild structural steel, or equal with written approval from Engineered Supply. Base material shall be weldable with E70xx electrodes and capable of supporting the loads shown in accordance with the current applicable codes for the project location.

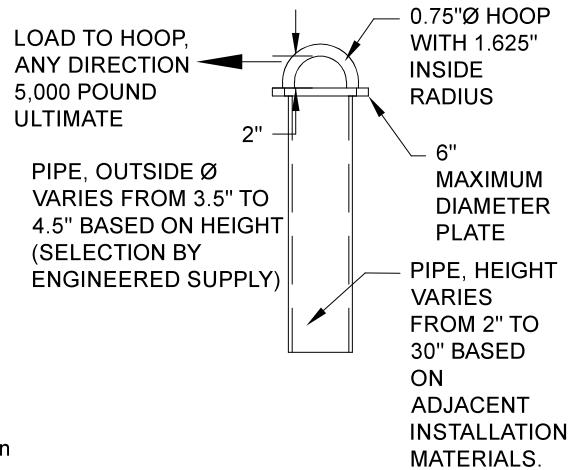

ANCHOR WELDING

Anchor welds shall consist of 3/16", 1/4" or 5/16" leg length field placed fillet welds. Anchor throat thickness varies based on pipe height, and shall be determined by the base material for the specific installation. Anchor welds shall be made with E70xx material, or equal weld filler material. All welds shall be in strict accordance to AWS requirements, including welds completed by a certified welder and qualified process with inspection under a Certified Welding Inspector (CWI). Field welds shall be prepared and field touch up painted with zinc rich paint by others.

WELDED PIPE ANCHOR ASSEMBLY

INSPECTION AND TRAINING

All fall protection and suspended maintenance equipment shall be selected or designed by others. Usage shall comply with the current version of the ANSI IWCA I14.1. Systems users to inspect all equipment prior to each use, including all visible attachment points, locks, and pins to ensure all equipment is in safe working order. All users shall be trained on proper use of the equipment, as well as knowing and complying with OSHA, ANSI and other pertinent life safety regulations. Equipment for rope descent and tie back use shall be initially load tested under the direction of a licensed engineer and annually inspected by a competent qualified person. Equipment shall be re-certified within 5 years.

STOCKED IN 12", 14", 16", 18", 24" AND 30" PIPE HEIGHTS, THESE STOCKED PRODUCTS ARE COMPLIANT WITH ANSI Z359.18-T, IBC, AISC, AWS, IWCA I-14.1, OSHA, AND CAL-OSHA.

BUILDING ENVELOPE

Installation and materials surrounding the anchor shall be designed by others in compliance with the applicable manufacturer's instructions and shall maintain the existing building warrantee as applicable. Flexible boots shall be provided at all roofing penetrations in accordance with the roofing manufacturer's instruction.

WELDED PIPE ANCHOR HXX"
 MODEL _____ PIPE HEIGHT (IN INCHES)
 12", 14", 16",
 18", 24", or 30"

ORDERING INFORMATION

 <p>ENGINEERED SUPPLY</p>	<p>STRONGTOP® Permanent Suspended Maintenance</p>		
	<p>ES P/N 901004-001</p>		
<p>DATA SHEET, WELDED PIPE ANCHOR, 5000 LB</p>			
<p>201 2ND AVE SOUTH BAYPORT, MINNESOTA 55003</p>		<p>651-439-0932 ENGINEEREDSUPPLY.COM</p>	
<p>SIZE 8.5x11</p>	<p>PATENT NO. D772040</p>	<p>DWG NO. 901004-001</p>	
<p>THIS DRAWING AND THE DESIGN SHOWN IS THE SOLE PROPERTY OF ENGINEERED SUPPLY.</p>		<p>SCALE 1" = 1'-0"</p>	<p>SHEET 1 of 1</p>

REVISIONS				
ZONE	REV	DESCRIPTION	DATE	APPROVED
-	2	ISSUED FOR USE (10 YEAR UPDATE)	11/13/2023	APG

GENERAL NOTES

The installation contractor is solely responsible for site safety. Site visits by Engineered Supply do not include review of the contractor's safety precautions. Installation drawings documenting the base materials and anchor bolts shall be provided by others and shall be reviewed by an experienced licensed engineer for all tieback and rope descent systems, or by a competent qualified person for all fall protection systems.

BASE MATERIALS Base material shall be structural steel, precast concrete, cast in place concrete, or equal with written approval from Engineered Supply. Base material shall be capable of supporting the loads shown in accordance with the current applicable codes for the project location.

ANCHOR BOLTS Anchor bolts shall be strictly per Engineered Supply's recommendations or reviewed by an experienced licensed engineer. Anchor bolts shall consist of 2- 1/2"Ø 300 series stainless steel or hot dipped galvanized steel materials. Anchor bolt embedment varies, and shall be determined by the base material for the specific installation. Anchoring systems shall be Hilti HY270 adhesive, Hilti HY200 adhesive, Hilti HDA Undercut, Hilti Kwik Bolt TZ, cast in place threaded rods with embedded double nuts and washer, through bolt or equal anchor with written approval from Engineered Supply. All anchors shall be installed in strict accordance with the anchor manufacturer's instruction. 100% of adhesive anchors require tensile pull test to a force equivalent to the test load. Anchor bolts shall have deformed thread nuts, or permanent thread locking chemical to prevent loosening. Anchor fasteners shall be torqued with a calibrated wrench in accordance to the anchor manufacturer's literature.

INSPECTION AND TRAINING All fall protection and suspended maintenance equipment shall be selected or designed by others. Usage shall comply with the current version of the ANSI IWCA 114.1. Systems users to inspect all equipment prior to each use, including all visible attachment points, locks, and pins to ensure all equipment is in safe working order. All users shall be trained on proper use of the equipment, as well as knowing and complying with OSHA, ANSI and other pertinent life safety regulations. Equipment for rope descent and tie back use shall be initially load tested under the direction of a licensed engineer and annually inspected by a competent qualified person. Equipment shall be re-certified within 5 years.

BUILDING ENVELOPE Installation and materials surrounding the anchor shall be designed by others in compliance with the applicable manufacturer's instructions and shall maintain the existing building warrantee as applicable.

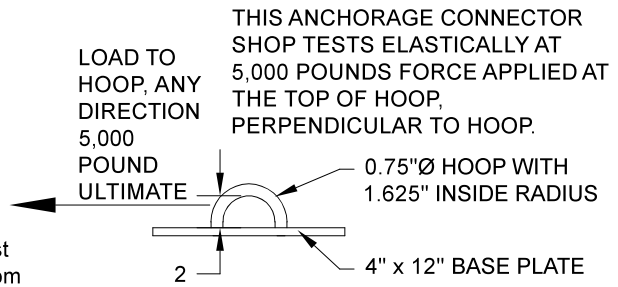

STANDARD PLATE ANCHOR ASSEMBLY

STOCKED IN HOT DIP GALVANIZED, 304 STAINLESS, OR 316 STAINLESS, THESE STOCKED PRODUCTS ARE COMPLIANT WITH ANSI Z359.18-T, IBC, AISC, AWS, IWCA I-14.1, OSHA, AND CAL-OSHA.

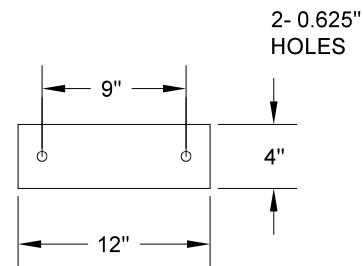

BASE PLATE HOLE PATTERN
PLATE THICKNESS IS 0.5"

STANDARD PLATE ANCHOR - XXXXXXXXXXXXX

MODEL _____

FINISH OPTIONS:
HOT DIP GALVANIZED
304 STAINLESS
316 STAINLESS

OPTION TO ADD 1/4", 1/2", OR 1" THERMAL INSULATION

ORDERING INFORMATION

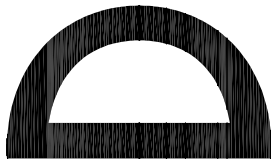

ENGINEERED SUPPLY

201 2ND AVE SOUTH
BAYPORT, MINNESOTA 55003

651-439-0932
ENGINEEREDSUPPLY.COM

THIS DRAWING AND THE DESIGN SHOWN IS THE SOLE PROPERTY OF ENGINEERED SUPPLY.

STRONGTOP®		
Permanent Suspended Maintenance		
ES P/N 902001-001		
DATA SHEET, STANDARD PLATE ANCHOR, 5000 LB, 2- HOLE, 9" GAGE		
SIZE	-	DWG NO.
8.5x11	-	902001-001
SCALE	1" = 1'-0"	SHEET 1 of 1

REVISIONS				
ZONE	REV	DESCRIPTION	DATE	APPROVED
-	2	ISSUED FOR USE (10 YEAR UPDATE)	11/15/2023	APG

GENERAL NOTES

The installation contractor is solely responsible for site safety. Site visits by Engineered Supply do not include review of the contractor's safety precautions. Installation drawings documenting the base materials and welds shall be provided by others and shall be reviewed by an experienced licensed engineer for all tieback and rope descent systems, or by a competent qualified person for all fall protection systems.

THIS ANCHORAGE CONNECTOR SHOP TESTS ELASTICALLY AT 5,000 POUNDS FORCE APPLIED AT THE TOP OF HOOP, PERPENDICULAR TO HOOP.

BASE MATERIALS

Base material shall be mild structural steel, or equal with written approval from Engineered Supply. Base material shall be weldable with E70xx electrodes and capable of supporting the loads shown in accordance with the current applicable codes for the project location.

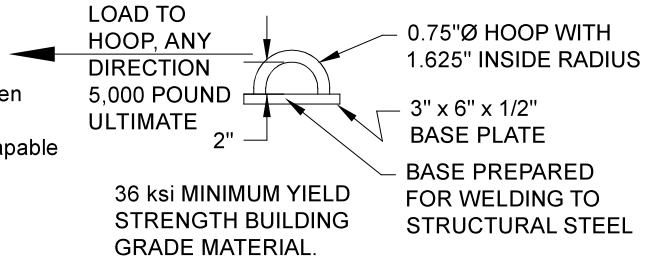

ANCHOR WELDING

Anchor welds shall consist of 3/16", 1/4" or 5/16" leg length field placed fillet welds. Anchor throat thickness varies based on pipe height, and shall be determined by the base material for the specific installation. Anchor welds shall be made with E70xx material, or equal weld filler material. All welds shall be in strict accordance to AWS requirements, including welds completed by a certified welder and qualified process with inspection under a Certified Welding Inspector (CWI). Field welds shall be prepared and field touch up painted with zinc rich paint by others.

WELDED PLATE ANCHOR ASSEMBLY

INSPECTION AND TRAINING

All fall protection and suspended maintenance equipment shall be selected or designed by others. Usage shall comply with the current version of the ANSI IWCA I14.1. Systems users to inspect all equipment prior to each use, including all visible attachment points, locks, and pins to ensure all equipment is in safe working order. All users shall be trained on proper use of the equipment, as well as knowing and complying with OSHA, ANSI and other pertinent life safety regulations. Equipment for rope descent and tie back use shall be initially load tested under the direction of a licensed engineer and annually inspected by a competent qualified person. Equipment shall be re-certified within 5 years.

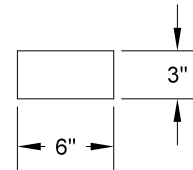

BASE PLATE VIEW

BUILDING ENVELOPE

Installation and materials surrounding the anchor shall be designed by others in compliance with the applicable manufacturer's instructions and shall maintain the existing building warrantee as applicable. Flexible boots shall be provided at all roofing penetrations in accordance with the roofing manufacturer's instruction.

WELDED PLATE ANCHOR
MODEL _____

ORDERING INFORMATION

	<p>ENGINEERED SUPPLY</p>	<p>STRONGTOP® Permanent Suspended Maintenance</p>		
		<p>ES P/N 902004-001</p>		
<p>201 2ND AVE SOUTH BAYPORT, MINNESOTA 55003</p>		<p>651-439-0932 ENGINEEREDSUPPLY.COM</p>		<p>DATA SHEET, WELDED PLATE ANCHOR, 5000 LB</p>
<p>THIS DRAWING AND THE DESIGN SHOWN IS THE SOLE PROPERTY OF ENGINEERED SUPPLY.</p>		<p>SIZE 8.5x11 -</p>	<p>DWG NO. 902004-001</p>	<p>SCALE 1" = 1'-0"</p>
			<p>SHEET 1 of 1</p>	

REVISIONS				
ZONE	REV	DESCRIPTION	DATE	APPROVED
-	2	ISSUED FOR USE (10 YEAR UPDATE)	11/15/2023	APG

GENERAL NOTES

The installation contractor is solely responsible for site safety. Site visits by Engineered Supply do not include review of the contractor's safety precautions. Installation drawings documenting the base materials and anchor bolts shall be provided by others and shall be reviewed by an experienced licensed engineer for all tieback and rope descent systems, or by a competent qualified person for all fall protection systems.

BASE MATERIALS Base material shall be masonry, structural steel, precast concrete, cast in place concrete, or equal with written approval from Engineered Supply. Base material shall be capable of supporting the loads shown in accordance with the current applicable codes for the project location.

ANCHOR BOLTS Anchor bolts shall be strictly per Engineered Supply's recommendations or reviewed by an experienced licensed engineer. Anchor bolts shall consist of 2- 3/4"Ø 300 series stainless steel or hot dipped galvanized steel materials. Anchor bolt embedment varies, and shall be determined by the base material for the specific installation. Anchoring systems shall be Hilti HY270 adhesive, Hilti HY200 adhesive, Hilti HDA Undercut, Hilti Kwik Bolt TZ, cast in place threaded rods with embedded double nuts and washer, through bolt or equal anchor with written approval from Engineered Supply. All anchors shall be installed in strict accordance with the anchor manufacturer's instruction. 100% of adhesive anchors require tensile pull test to a force equivalent to the test load. Anchor bolts shall have deformed thread nuts, or permanent thread locking chemical to prevent loosening. Anchor fasteners shall be torqued with a calibrated wrench in accordance to the anchor manufacturer's literature.

INSPECTION AND TRAINING All fall protection and suspended maintenance equipment shall be selected or designed by others. Usage shall comply with the current version of the ANSI IWCA I14.1. Systems users to inspect all equipment prior to each use, including all visible attachment points, locks, and pins to ensure all equipment is in safe working order. All users shall be trained on proper use of the equipment, as well as knowing and complying with OSHA, ANSI and other pertinent life safety regulations. Equipment for rope descent and tie back use shall be initially load tested under the direction of a licensed engineer and annually inspected by a competent qualified person. Equipment shall be re-certified within 5 years.

BUILDING ENVELOPE Installation and materials surrounding the anchor shall be designed by others in compliance with the applicable manufacturer's instructions and shall maintain the existing building warrantee as applicable.

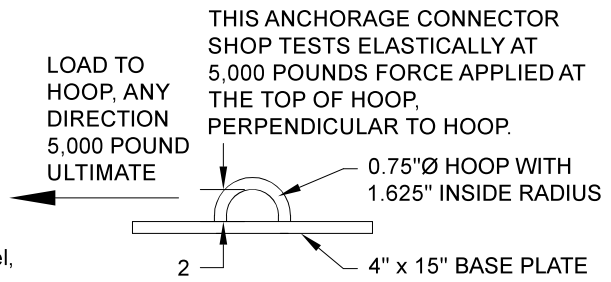

WIDE PLATE ANCHOR ASSEMBLY

THIS HOT DIP GALVANIZED STOCKED PRODUCT IS COMPLIANT WITH ANSI Z359.18-T, IBC, AISC, AWS, IWCA I-14.1, OSHA, AND CAL-OSHA.

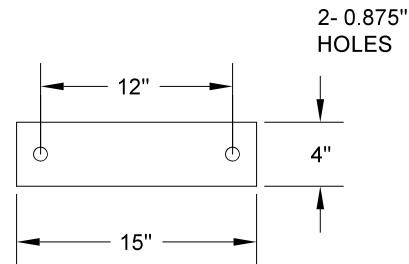

BASE PLATE HOLE PATTERN
PLATE THICKNESS IS 0.75"

WIDE PLATE ANCHOR MODEL _____

ORDERING INFORMATION

 <p>ENGINEERED SUPPLY</p>	<p>STRONGTOP® Permanent Suspended Maintenance</p>		
	<p>ES P/N 902002-001</p>		
<p>DATA SHEET, WIDE PLATE ANCHOR, 5000 LB, 2- HOLE, 12" GAGE</p>			
<p>201 2ND AVE SOUTH BAYPORT, MINNESOTA 55003</p>		<p>651-439-0932 ENGINEEREDSUPPLY.COM</p>	
<p>SIZE 8.5x11</p>	<p>-</p>	<p>DWG NO. 902002-001</p>	
<p>SCALE 1" = 1'-0"</p>		<p>SHEET 1 of 1</p>	
<p>THIS DRAWING AND THE DESIGN SHOWN IS THE SOLE PROPERTY OF ENGINEERED SUPPLY.</p>			

REVISIONS				
ZONE	REV	DESCRIPTION	DATE	APPROVED
-	2	ISSUED FOR USE (10 YEAR UPDATE)	11/12/2023	APG

GENERAL NOTES

The installation contractor is solely responsible for site safety. Site visits by Engineered Supply do not include review of the contractor's safety precautions. Installation drawings documenting the base materials and anchor bolts shall be provided by others and shall be reviewed by an experienced licensed engineer for all tieback and rope descent systems, or by a competent qualified person for all fall protection systems.

BASE MATERIALS Base material shall be capable of supporting the loads shown in accordance with the current applicable codes for the project location.

ANCHOR BOLTS

All anchors shall be installed in strict accordance with the anchor manufacturer's instruction.

Anchor fasteners shall be torqued with a calibrated wrench in accordance to the anchor manufacturer's literature.

INSPECTION AND TRAINING All fall protection and suspended maintenance equipment shall be selected or designed by others.

Usage shall comply with the current version of the ANSI IWCA I14.1. Systems users to inspect all equipment prior to each use, including all visible attachment points, locks, and pins to ensure all equipment is in safe working order. All users shall be trained on proper use of the equipment, as well as knowing and complying with OSHA, ANSI and other pertinent life safety regulations.

Equipment for rope descent and tie back use shall be initially load tested under the direction of a licensed engineer and annually inspected by a competent qualified person. Equipment shall be re-certified within 5 years.

BUILDING ENVELOPE Installation and materials surrounding the anchor shall be designed by others in compliance with the applicable manufacturer's instructions and shall maintain the existing building warrantee as applicable.

Flexible boots shall be provided at all roofing penetrations in accordance with the roofing manufacturer's instruction.

KEYED NOTES

- A. ENGINEERED SUPPLY STRONGTOP UNIVERSAL PIPE ANCHOR.
- B. CONCRETE SLAB, 4,000 PSI MINIMUM COMPRESSIVE STRENGTH (ASSUMED CRACKED CONCRETE).
- C. 1/2" DIAMETER HILTI TZ 304 STAINLESS STEEL EXPANSION BOLT WITH LOCTITE. SEE HILTI DATA FOR ADDITIONAL INSTALLATION REQUIREMENTS. SUPPLY BY ES WITH ANCHOR UNLESS NOTED OTHERWISE.
- D. ROOFING FLASHING PER ROOFING MANUFACTURER'S INSTRUCTION. SUPPLY BY INSTALLER UNLESS NOTED OTHERWISE.
- E. ACCEPTABLE TO LEAVE REMAINING HOLES OPEN.

LOAD TO HOOP, ANY DIRECTION
5,000 POUND ULTIMATE

THIS DETAIL SHOP TESTS ELASTICALLY AT 5,000 POUNDS FORCE APPLIED AT THE TOP OF HOOP.

SECTION VIEW

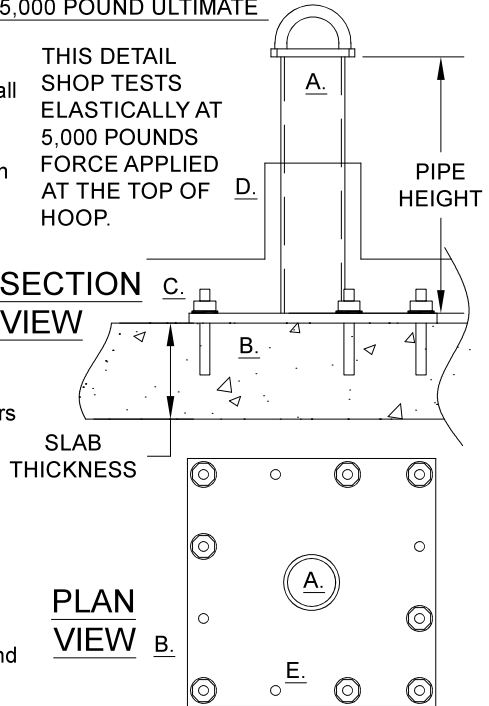

THIS DETAIL IS COMPLIANT WITH ANSI Z359.18-T, IBC, AISC, AWS, ACI, IWCA I-14.1, OSHA, AND CAL-OSHA.

GROUND PENETRATING RADAR SCANNING IS REQUIRED AT PRE AND POST TENSIONED STRUCTURES, RECOMMENDED AT ALL INSTALLATION LOCATIONS.

PIPE HEIGHT	MINIMUM SLAB THICKNESS FOR HILTI BOLTS	TOTAL NUMBER OF BOLTS	BOLTS EACH SIDE	MINIMUM HOLE DEPTH	MINIMUM BOLT LENGTH
14"	5.0"	4	2	3.25"	4.5"
18"	5.5"	4	2	4.25"	5.5"
	5.0"	8	3	3.25"	4.5"
24"	5.0"	12	4	3.25"	4.5"

SPECIFICALLY NOTE THAT THE MINIMUM SLAB THICKNESS INDICATES NECESSARY SLAB THICKNESS FOR THE GIVEN HILTI TZ EXPANSION BOLT DRILLED HOLE. THIS BASE MATERIAL IS REQUIRED TO BE FURTHER VERIFIED FOR THE APPLICABLE LOADS BY THE PROJECT ENGINEER FOR ROPE DESCENT AND TIEBACK, OR BY THE COMPETENT QUALIFIED PERSON FOR FALL PROTECTION.

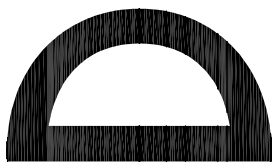

ENGINEERED SUPPLY

201 2ND AVE SOUTH
BAYPORT, MINNESOTA 55003

651-439-0932
ENGINEEREDSUPPLY.COM

STRONGTOP®

Permanent Suspended Maintenance

ES P/N 901002-511

GENERAL INSTALLATION DETAIL,
CONCRETE SLAB ATTACHMENT,
UNIVERSAL PIPE ANCHOR

SIZE	PATENT NO.	DWG NO.
8.5x11	D772040	901002-511

THIS DRAWING AND THE DESIGN SHOWN IS THE SOLE PROPERTY OF ENGINEERED SUPPLY.

SCALE 1" = 1'-0" SHEET 1 of 1

REVISIONS				
ZONE	REV	DESCRIPTION	DATE	APPROVED
-	2	ISSUED FOR USE (10 YEAR UPDATE)	11/13/2021	APG

GENERAL NOTES

The installation contractor is solely responsible for site safety. Site visits by Engineered Supply do not include review of the contractor's safety precautions. Installation drawings documenting the base materials and anchor bolts shall be provided by others and shall be reviewed by an experienced licensed engineer for all tieback and rope descent systems, or by a competent qualified person for all fall protection systems.

BASE MATERIALS Base material shall be capable of supporting the loads shown in accordance with the current applicable codes for the project location.

ANCHOR BOLTS

All anchors shall be installed in strict accordance with the anchor manufacturer's instruction.

Anchor fasteners shall be torqued with a calibrated wrench in accordance to the anchor manufacturer's literature.

INSPECTION AND TRAINING All fall protection and suspended maintenance equipment shall be selected or designed by others.

Usage shall comply with the current version of the ANSI IWCA 114.1. Systems users to inspect all equipment prior to each use, including all visible attachment points, locks, and pins to ensure all equipment is in safe working order. All users shall be trained on proper use of the equipment, as well as knowing and complying with OSHA, ANSI and other pertinent life safety regulations.

Equipment for rope descent and tie back use shall be initially load tested under the direction of a licensed engineer and annually inspected by a competent qualified person. Equipment shall be re-certified within 5 years.

BUILDING ENVELOPE Installation and materials surrounding the anchor shall be designed by others in compliance with the applicable manufacturer's instructions and shall maintain the existing building warrantee as applicable.

Flexible boots shall be provided at all roofing penetrations in accordance with the roofing manufacturer's instruction.

SPECIFICALLY NOTE THAT THE MINIMUM CONCRETE THICKNESS INDICATES NECESSARY SLAB THICKNESS FOR THE GIVEN HILTI TZ EXPANSION BOLT DRILLED HOLE. THIS BASE MATERIAL IS REQUIRED TO BE FURTHER VERIFIED FOR THE APPLICABLE LOADS BY THE PROJECT ENGINEER FOR ROPE DESCENT AND TIEBACK, OR BY THE COMPETENT QUALIFIED PERSON FOR FALL PROTECTION.

THIS DETAIL IS COMPLIANT WITH ANSI Z359.18-T, IBC, AISC, AWS, ACI, IWCA I-14.1, OSHA, AND CAL-OSHA.

GROUND PENETRATING RADAR SCANNING IS REQUIRED AT PRE AND POST TENSIONED STRUCTURES, RECOMMENDED AT ALL INSTALLATION LOCATIONS.

THIS DETAIL SHOP TESTS ELASTICALLY AT 5,000 POUNDS FORCE APPLIED AT THE TOP OF HOOP.

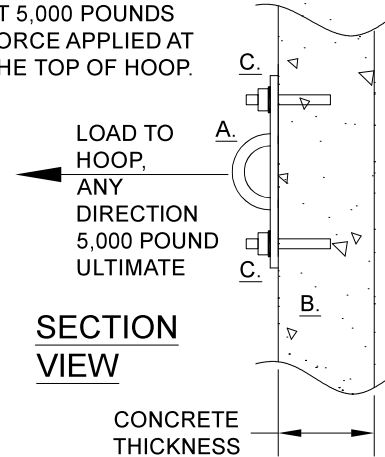

SECTION VIEW

ELEVATION VIEW

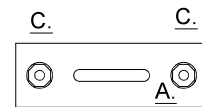

KEYED NOTES

- A.** ENGINEERED SUPPLY STRONGTOP STANDARD PLATE ANCHOR.
- B.** CONCRETE WALL, 4,000 PSI MINIMUM COMPRESSIVE STRENGTH, 5.5" MINIMUM THICKNESS, ASSUMED NON-CRACKED.
- C.** 1/2" DIAMETER x 5-1/2" LONG HILTI TZ 304 STAINLESS STEEL EXPANSION BOLT IN 4-1/4" DEEP HOLE (316 STAINLESS EXPANSION BOLT AT 316 STAINLESS ANCHORAGE CONNECTOR). SEE HILTI DATA FOR OTHER INSTALLATION REQUIREMENTS.

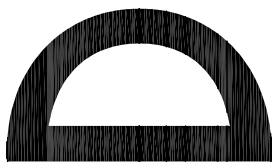

ENGINEERED SUPPLY

201 2ND AVE SOUTH
BAYPORT, MINNESOTA 55003

651-439-0932
ENGINEEREDSUPPLY.COM

THIS DRAWING AND THE DESIGN SHOWN IS THE SOLE PROPERTY OF ENGINEERED SUPPLY.

STRONGTOP®

Permanent Suspended Maintenance

ES P/N 902001-501

GENERAL INSTALLATION DETAIL,
CONCRETE WALL ATTACHMENT,
STANDARD PLATE ANCHOR

SIZE	PATENT NO.	DWG NO.
8.5x11	-	902001-501

SCALE 1" = 1'-0"	SHEET 1 of 1
------------------	--------------

REVISIONS				
ZONE	REV	DESCRIPTION	DATE	APPROVED
-	2	ISSUED FOR USE (10 YEAR UPDATE)	11/14/2023	APG

GENERAL NOTES

The installation contractor is solely responsible for site safety. Site visits by Engineered Supply do not include review of the contractor's safety precautions.

BASE MATERIALS Base material shall be structural building steel with a yield strength between 36 ksi and 50 ksi or equal with written approval from Engineered Supply.

Installation drawings documenting the base materials and welds shall be provided by others and shall be reviewed by an experienced site licensed engineer for all tieback and rope descent systems, or by a competent qualified person for all fall protection systems.

ANCHOR WELDING Anchor welds shall consist of 3/16", 1/4" or 5/16" leg length field placed fillet welds.

Anchor throat thickness varies based on pipe height, and shall be determined by the base material for the specific installation.

Anchor welds shall be made with E70xx material, or equal weld filler material.

All welds shall be in strict accordance to AWS requirements, including welds completed by a certified welder and qualified process with inspection under a Certified Welding Inspector (CWI).

Field welds shall be prepared and field touch up painted with zinc rich paint by others.

INSPECTION AND TRAINING All fall protection and suspended maintenance equipment shall be selected or designed by others.

Usage shall comply with the current version of the ANSI IWCA I14.1. Systems users to inspect all equipment prior to each use, including all visible attachment points, locks, and pins to ensure all equipment is in safe working order. All users shall be trained on proper use of the equipment, as well as knowing and complying with OSHA, ANSI and other pertinent life safety regulations.

Equipment for rope descent and tie back use shall be initially load tested under the direction of a licensed engineer and annually inspected by a competent qualified person. Equipment shall be re-certified within 5 years

BUILDING ENVELOPE Installation and materials surrounding the anchor shall be designed by others in compliance with the applicable manufacturer's instructions and shall maintain the existing building warrantee as applicable.

Flexible boots shall be provided at all roofing penetrations in accordance with the roofing manufacturer's instruction.

Touch up blemishes in hot dip finish with zinc rich paint, supply by installer.

SPECIFICALLY NOTE THAT THE INFORMATION GIVEN ARE MINIMUMS FOR THE ANCHORAGE ATTACHMENT. THIS BASE MATERIAL IS REQUIRED TO BE FURTHER VERIFIED FOR THE APPLICABLE LOADS BY THE PROJECT ENGINEER FOR ROPE DESCENT AND TIEBACK, OR BY THE COMPETENT QUALIFIED PERSON FOR FALL PROTECTION.

ELECTRODES, STIFFENER PLATES, ANGLE BRACE, STRUCTURAL STEEL, AND ROOFING BY INSTALLER, UNLESS NOTED OTHERWISE, TYPICAL.

STOCKED IN 12", 14", 16", AND 18" PIPE HEIGHTS, THESE STOCKED PRODUCTS ARE COMPLIANT WITH ANSI Z359.18-T, IBC, AISC, AWS, IWCA I-14.1, OSHA, AND CAL-OSHA.

THIS ANCHORAGE CONNECTOR DETAIL SHOP TESTS ELASTICALLY AT 5,000 POUNDS FORCE APPLIED AT THE TOP OF HOOP, PERPENDICULAR TO HOOP.

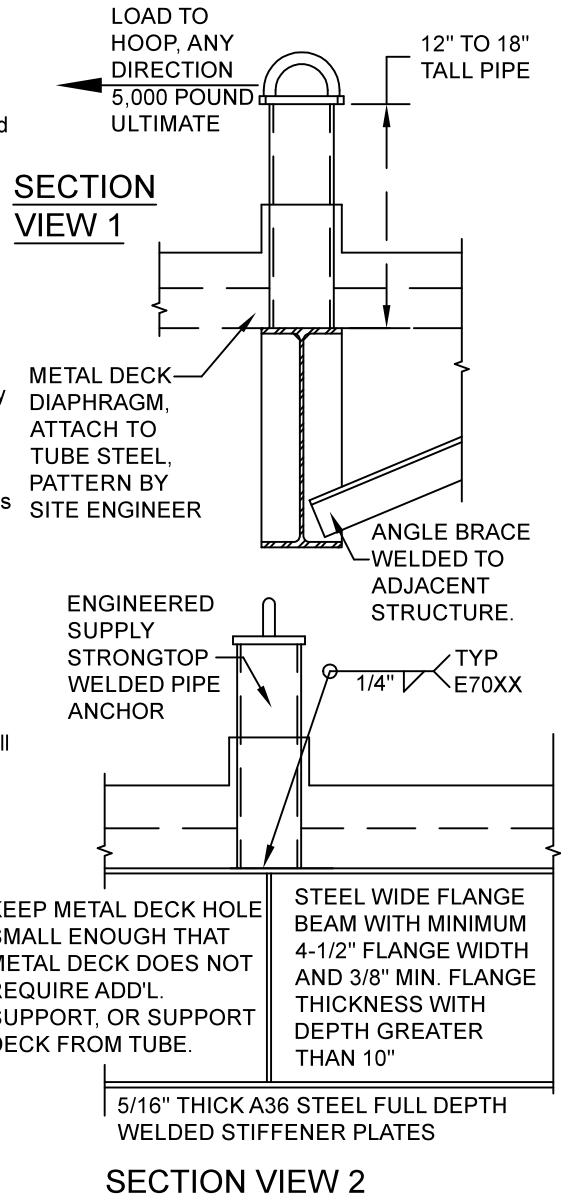

ENGINEERED SUPPLY

201 2ND AVE SOUTH
BAYPORT, MINNESOTA 55003

651-439-0932
ENGINEEREDSUPPLY.COM

THIS DRAWING AND THE DESIGN SHOWN IS THE SOLE PROPERTY OF ENGINEERED SUPPLY.

STRONGTOP®

Permanent Suspended Maintenance

ES P/N 901004-501

GENERAL INSTALLATION DETAIL,
STEEL WIDE FLANGE BEAM
ATTACHMENT, WELDED PIPE ANCHOR

SIZE

8.5x11

PATENT NO.

D772040

DWG NO.

901004-501

SCALE 1" = 1'-0"

SHEET 1 of 1

REVISIONS				
ZONE	REV	DESCRIPTION	DATE	APPROVED
-	2	ISSUED FOR USE (10 YEAR UPDATE)	11/15/2023	APG

GENERAL NOTES

The installation contractor is solely responsible for site safety. Site visits by Engineered Supply do not include review of the contractor's safety precautions.

BASE MATERIALS Base material shall be structural building steel with a yield strength between 36 ksi and 50 ksi or equal with written approval from Engineered Supply.

Installation drawings documenting the base materials and welds shall be provided by others and shall be reviewed by an experienced site licensed engineer for all tieback and rope descent systems, or by a competent qualified person for all fall protection systems.

ANCHOR WELDING Anchor welds shall consist of 3/16", 1/4" or 5/16" leg length field placed fillet welds.

Anchor throat thickness varies based on pipe height, and shall be determined by the base material for the specific installation.

Anchor welds shall be made with E70xx material, or equal weld filler material. All welds shall be in strict accordance to AWS requirements, including welds completed by a certified welder and qualified process with inspection under a Certified Welding Inspector (CWI).

Field welds shall be prepared and field touch up painted with zinc rich paint by others.

INSPECTION AND TRAINING All fall protection and suspended maintenance equipment shall be selected or designed by others.

Usage shall comply with the current version of the ANSI IWCA I14.1. Systems users to inspect all equipment prior to each use, including all visible attachment points, locks, and pins to ensure all equipment is in safe working order. All users shall be trained on proper use of the equipment, as well as knowing and complying with OSHA, ANSI and other pertinent life safety regulations.

Equipment for rope descent and tie back use shall be initially load tested under the direction of a licensed engineer and annually inspected by a competent qualified person. Equipment shall be re-certified within 5 years

BUILDING ENVELOPE Installation and materials surrounding the anchor shall be designed by others in compliance with the applicable manufacturer's instructions and shall maintain the existing building warranty as applicable.

Touch up blemishes in hot dip finish with zinc rich paint, supply by installer.

SPECIFICALLY NOTE THAT THE INFORMATION GIVEN ARE MINIMUMS FOR THE ANCHORAGE ATTACHMENT. THIS BASE MATERIAL IS REQUIRED TO BE FURTHER VERIFIED FOR THE APPLICABLE LOADS BY THE PROJECT ENGINEER FOR ROPE DESCENT AND TIEBACK, OR BY THE COMPETENT QUALIFIED PERSON FOR FALL PROTECTION.

ELECTRODES, STIFFENER PLATES, ANGLE BRACE, STRUCTURAL STEEL, AND ROOFING BY INSTALLER, UNLESS NOTED OTHERWISE, TYPICAL.

THIS STOCKED PRODUCT IS COMPLIANT WITH ANSI Z359.18-T, IBC, AISC, AWS, IWCA I-14.1, OSHA, AND CAL-OSHA.

THIS ANCHORAGE CONNECTOR DETAIL SHOP TESTS ELASTICALLY AT 5,000 POUNDS FORCE APPLIED AT THE TOP OF HOOP, PERPENDICULAR TO HOOP.

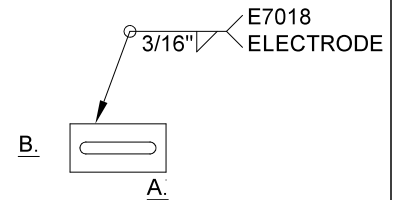
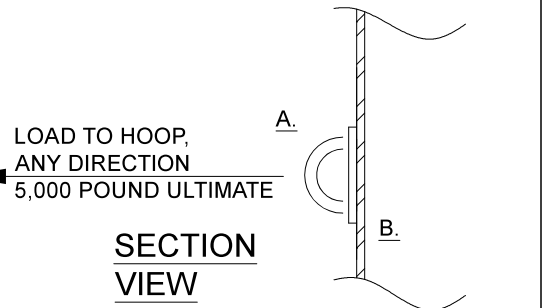

KEYED NOTES

- A. ENGINEERED SUPPLY STRONGTOP WELDED PLATE ANCHOR.
- B. STRUCTURAL STEEL BASE MATERIAL.

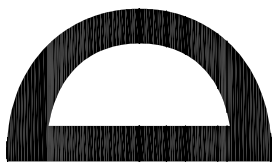

ENGINEERED SUPPLY

201 2ND AVE SOUTH
BAYPORT, MINNESOTA 55003

651-439-0932
ENGINEEREDSUPPLY.COM

THIS DRAWING AND THE DESIGN SHOWN IS THE SOLE PROPERTY OF ENGINEERED SUPPLY.

STRONGTOP®

Permanent Suspended Maintenance

ES P/N 902004-501

GENERAL INSTALLATION DETAIL,
STRUCTURAL STEEL ATTACHMENT,
WELDED PLATE ANCHOR

SIZE 8.5x11 - DWG NO. 902004-501

SCALE 1" = 1'-0" SHEET 1 of 1

REVISIONS				
ZONE	REV	DESCRIPTION	DATE	APPROVED
-	2	ISSUED FOR USE (10 YEAR UPDATE)	11/18/23	APG

GENERAL NOTES

The installation contractor is solely responsible for site safety. Site visits by Engineered Supply do not include review of the contractor's safety precautions.

Installation drawings documenting the base materials shall be provided by others and shall be reviewed by an experienced licensed engineer for all tieback and rope descent systems, or by a competent qualified person for all fall protection systems.

BASE MATERIALS Base material shall be capable of supporting the loads shown in accordance with the current applicable codes for the project location. Base material shall be 2x nominal top chord trusses at 16" to 24" on center with 7/16" to 3/4" thick plywood / osb, or equal with written approval from Engineered Supply.

ANCHOR BOLTS

All anchors shall be installed in strict accordance with the anchor manufacturer's instruction. Anchor fasteners shall be tightened until all surfaces are in direct contact and wood is lightly indented at edge of washer or screw head. Do not overdrive fasteners.

INSPECTION AND TRAINING All fall protection and suspended maintenance equipment shall be selected or designed by others. Usage shall comply with the current version of the ANSI IWCA I14.1. Systems users to inspect all equipment prior to each use, including all visible attachment points, locks, and pins to ensure all equipment is in safe working order. All users shall be trained on proper use of the equipment, as well as knowing and complying with OSHA, ANSI and other pertinent life safety regulations.

Equipment for rope descent and tie back use shall be initially load tested under the direction of a licensed engineer and annually inspected by a competent qualified person. Equipment shall be re-certified within 5 years.

BUILDING ENVELOPE

Installation and materials surrounding the anchor shall be designed by others in compliance with the applicable manufacturer's instructions and shall maintain the existing building warrantee as applicable.

Flexible boots shall be provided at all roofing penetrations in accordance with the roofing manufacturer's instruction.

THIS DETAIL SHOP TESTS ELASTICALLY AT 5,000 POUNDS FORCE APPLIED AT THE TOP OF HOOP.

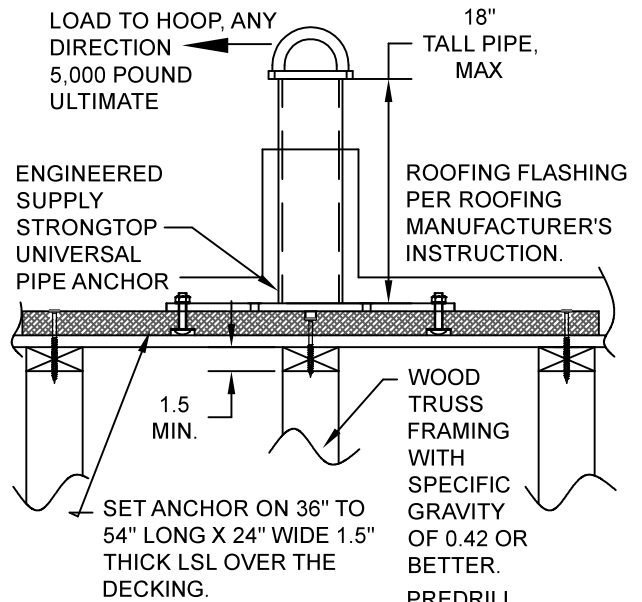

THIS DETAIL IS COMPLIANT WITH ANSI Z359.18-T, IBC, AISC, AWS, NDS, IWCA I-14.1, OSHA, AND CAL-OSHA.

SECTION VIEW

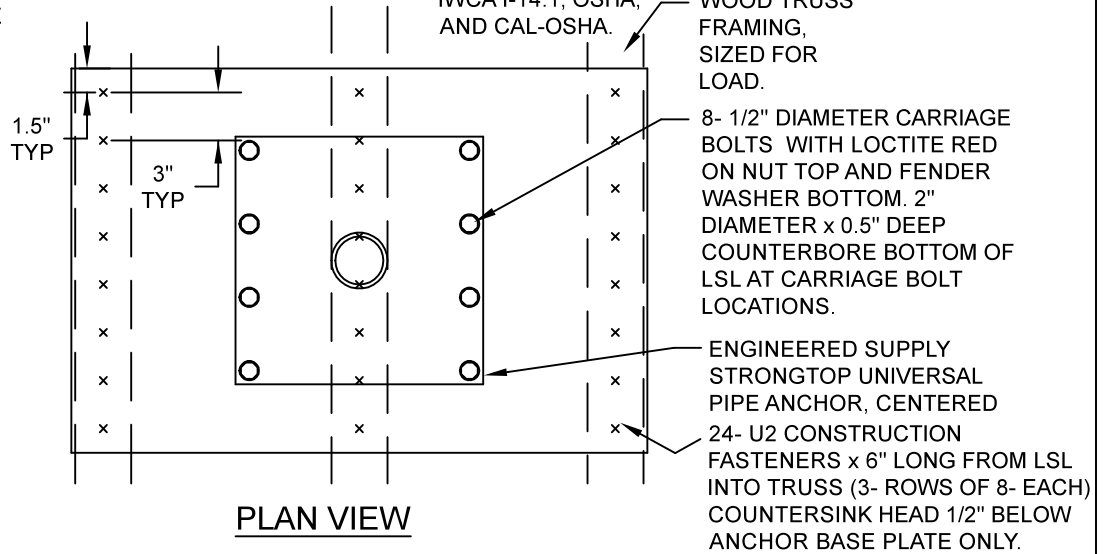

PLAN VIEW

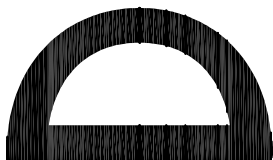

ENGINEERED SUPPLY

201 2ND AVE SOUTH
BAYPORT, MINNESOTA 55003

651-439-0932
ENGINEEREDSUPPLY.COM

STRONGTOP™

Permanent Suspended Maintenance

ES P/N 901002-518d

GENERAL INSTALLATION DETAIL,
WOOD TRUSS FRAMING ATTACHMENT,
UNIVERSAL PIPE ANCHOR

SIZE	PATENT NO.	DWG NO.
8.5x11	D772040	901002-518d

THIS DRAWING AND THE DESIGN SHOWN IS THE SOLE PROPERTY OF ENGINEERED SUPPLY.

SCALE 1" = 1'-0" SHEET 1 of 1

REVISIONS				
ZONE	REV	DESCRIPTION	DATE	APPROVED
-	2	ISSUED FOR USE (10 YEAR UPDATE)	11/19/23	APG

GENERAL NOTES

The installation contractor is solely responsible for site safety. Site visits by Engineered Supply do not include review of the contractor's safety precautions.

Installation drawings documenting the base materials shall be provided by others and shall be reviewed by an experienced licensed engineer for all tieback and rope descent systems, or by a competent qualified person for all fall protection systems.

BASE MATERIALS Base material shall be capable of supporting the loads shown in accordance with the current applicable codes for the project location. Base material shall be 2x nominal top chord trusses at 16" to 24" on center with 7/16" to 3/4" thick plywood / osb, or equal with written approval from Engineered Supply.

ANCHOR BOLTS
All anchors shall be installed in strict accordance with the anchor manufacturer's instruction. Anchor fasteners shall be tightened until all surfaces are in direct contact and wood is lightly indented at edge of washer or screw head. Do not overdrive fasteners.

INSPECTION AND TRAINING All fall protection and suspended maintenance equipment shall be selected or designed by others. Usage shall comply with the current version of the ANSI IWCA 114.1. Systems users to inspect all equipment prior to each use, including all visible attachment points, locks, and pins to ensure all equipment is in safe working order. All users shall be trained on proper use of the equipment, as well as knowing and complying with OSHA, ANSI and other pertinent life safety regulations. Equipment for rope descent and tie back use shall be initially load tested under the direction of a licensed engineer and annually inspected by a competent qualified person. Equipment shall be re-certified within 5 years.

BUILDING ENVELOPE
Installation and materials surrounding the anchor shall be designed by others in compliance with the applicable manufacturer's instructions and shall maintain the existing building warrantee as applicable. Flexible boots shall be provided at all roofing penetrations in accordance with the roofing manufacturer's instruction.

THIS DETAIL SHOP TESTS ELASTICALLY AT 5,000 POUNDS FORCE APPLIED AT THE TOP OF HOOP.

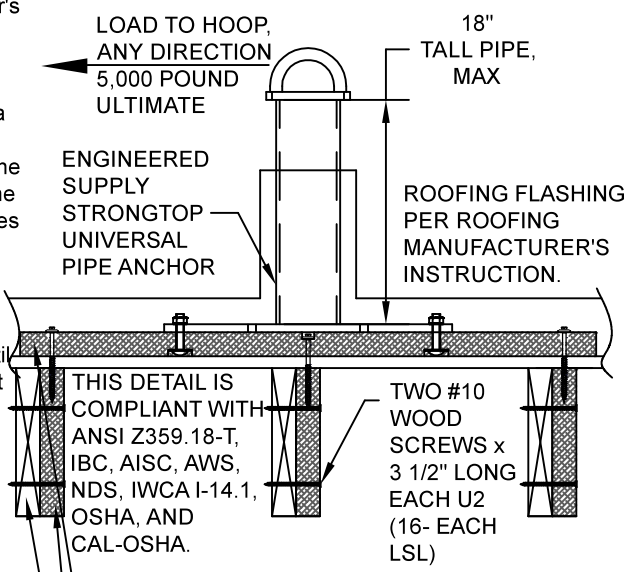

SECTION VIEW

THIS DETAIL IS COMPLIANT WITH ANSI Z359.18-T, IBC, AISC, AWS, NDS, IWCA I-14.1, OSHA, AND CAL-OSHA.

SET ANCHOR ON 36" TO 52" LONG X 24" WIDE 1.5" THICK LSL OVER THE DECKING.

1.5" x MATCHING DEPTH LSL SISTERED TO 2x FRAMING

WOOD FRAMING WITH SPECIFIC GRAVITY OF 0.42 OR BETTER

2x FRAMING, SIZED FOR LOAD BY OTHERS

8- 1/2" DIAMETER CARRIAGE BOLTS WITH LOCTITE RED ON NUT TOP AND FENDER WASHER BOTTOM. 2" DIAMETER x 0.5" DEEP COUNTERBORE BOTTOM OF LSL AT CARRIAGE BOLT LOCATIONS.

24- U2 CONSTRUCTION FASTENERS x 6" LONG FROM LSL PLINTH INTO LSL BLOCKING (3- ROWS OF 8- EACH) COUNTERSINK HEAD 1/2" BELOW ANCHOR BASE PLATE

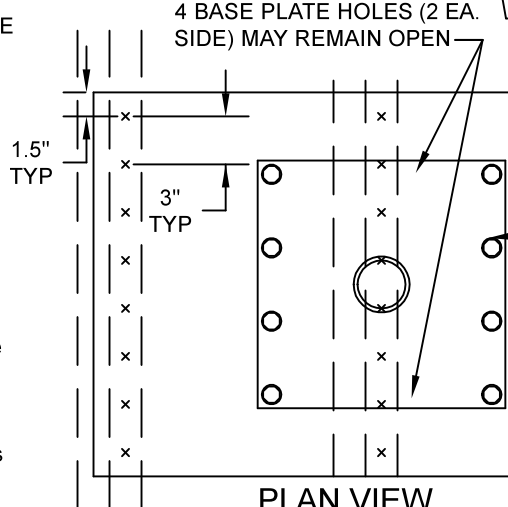

PLAN VIEW



ENGINEERED SUPPLY

201 2ND AVE SOUTH
BAYPORT, MINNESOTA 55003

651-439-0932
ENGINEEREDSUPPLY.COM

STRONGTOP™

Permanent Suspended Maintenance

ES P/N 901002-518f

GENERAL INSTALLATION DETAIL,
WOOD FRAMING ATTACHMENT,
UNIVERSAL PIPE ANCHOR

SIZE	PATENT NO.	DWG NO.
8.5x11	D772040	901002-518f

THIS DRAWING AND THE DESIGN SHOWN IS THE SOLE PROPERTY OF ENGINEERED SUPPLY.

SCALE 1" = 1'-0" SHEET 1 of 1

REVISIONS				
ZONE	REV	DESCRIPTION	DATE	APPROVED
-	2	ISSUED FOR USE (10 YEAR UPDATE)	11/19/23	APG

GENERAL NOTES

The installation contractor is solely responsible for site safety. Site visits by Engineered Supply do not include review of the contractor's safety precautions.

Installation drawings documenting the base materials shall be provided by others and shall be reviewed by an experienced licensed engineer for all tieback and rope descent systems, or by a competent qualified person for all fall protection systems. **BASE MATERIALS** Base material shall be capable of supporting the loads shown in accordance with the current applicable codes for the project location. Base material shall be 2x nominal top chord trusses at 16" to 24" on center with 7/16" to 3/4" thick plywood / osb, or equal with written approval from Engineered Supply.

ANCHOR BOLTS

All anchors shall be installed in strict accordance with the anchor manufacturer's instruction. Anchor fasteners shall be tightened until all surfaces are in direct contact and wood is lightly indented at edge of washer or screw head. Do not overdrive fasteners.

INSPECTION AND TRAINING All fall protection and suspended maintenance equipment shall be selected or designed by others. Usage shall comply with the current version of the ANSI IWCA 114.1. Systems users to inspect all equipment prior to each use, including all visible attachment points, locks, and pins to ensure all equipment is in safe working order. All users shall be trained on proper use of the equipment, as well as knowing and complying with OSHA, ANSI and other pertinent life safety regulations.

Equipment for rope descent and tie back use shall be initially load tested under the direction of a licensed engineer and annually inspected by a competent qualified person. Equipment shall be re-certified within 5 years.

BUILDING ENVELOPE

Installation and materials surrounding the anchor shall be designed by others in compliance with the applicable manufacturer's instructions and shall maintain the existing building warrantee as applicable. Flexible boots shall be provided at all roofing penetrations in accordance with the roofing manufacturer's instruction.

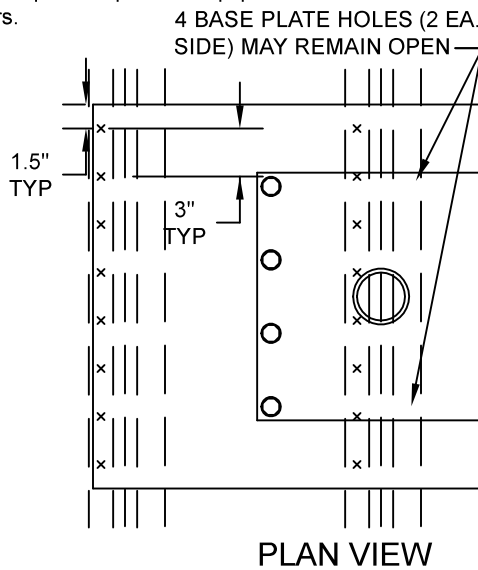
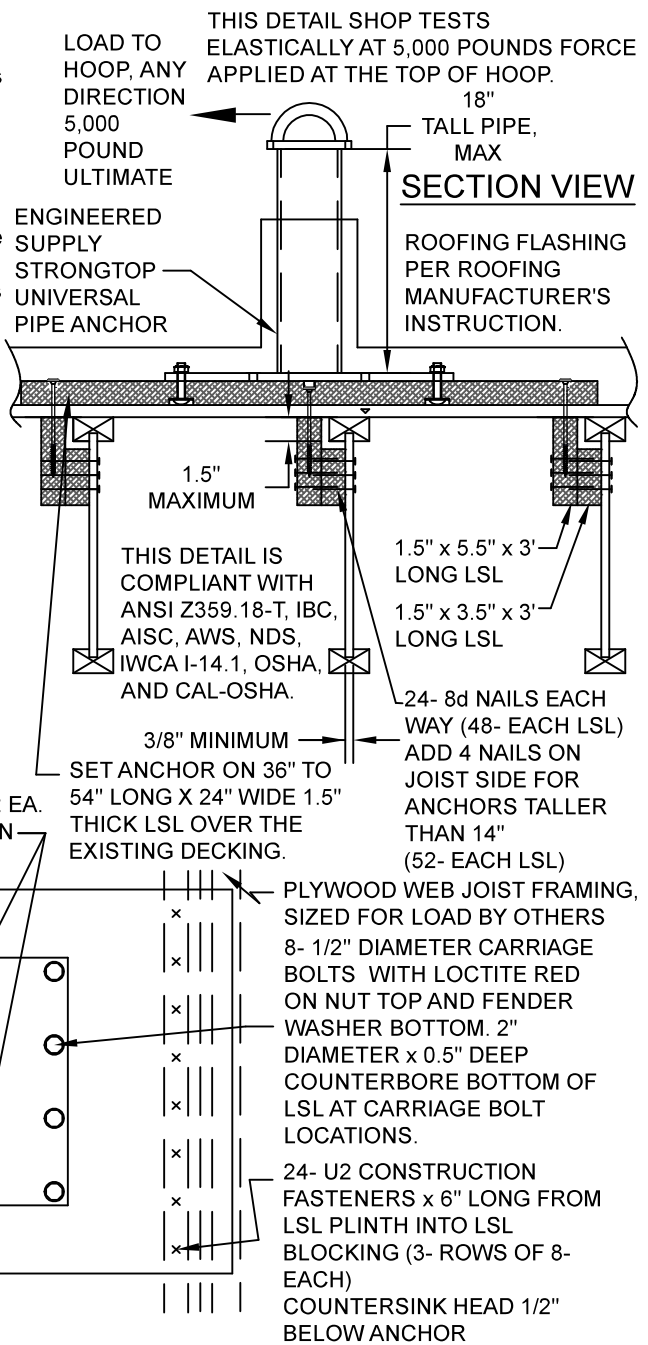

ENGINEERED SUPPLY

201 2ND AVE SOUTH
BAYPORT, MINNESOTA 55003

651-439-0932
ENGINEEREDSUPPLY.COM

THIS DRAWING AND THE DESIGN SHOWN IS THE SOLE PROPERTY OF ENGINEERED SUPPLY.

STRONGTOP™

Permanent Suspended Maintenance

ES P/N 901002-518c

GENERAL INSTALLATION DETAIL,
WOOD I JOIST FRAMING ATTACHMENT,
UNIVERSAL PIPE ANCHOR

SIZE

8.5x11

PATENT NO.

D772040

DWG NO.

901002-518c

SCALE 1" = 1'-0"

SHEET

1 of 1

REVISIONS				
ZONE	REV	DESCRIPTION	DATE	APPROVED
-	1	ISSUED FOR USE	02/05/25	APG

GENERAL NOTES

The installation contractor is solely responsible for site safety. Site visits by Engineered Supply do not include review of the contractor's safety precautions.

BASE MATERIALS

Base material shall be cross-laminated timber (CLT) planks with minimum 3-ply layup, or equal with written approval from Engineered Supply.

Base materials shall be reviewed by an experienced licensed engineer (additional hold downs at bearings are typically required).

INSPECTION AND TRAINING

All fall protection and suspended maintenance equipment shall be selected or designed by others.

Usage shall comply with the current version of the ANSI IWCA I14.1. Systems users to inspect all equipment prior to each use, including all visible attachment points, locks, and pins to ensure all equipment is in safe working order. All users shall be trained on proper use of the equipment, as well as knowing and complying with OSHA, ANSI, and other pertinent life safety regulations.

Equipment shall be initially load tested, annually inspected by a qualified person, and also re-certified within 5 years under direct supervision of an experienced licensed engineer.

BUILDING ENVELOPE

Installation and materials surrounding the anchor shall be designed by others in compliance with the applicable manufacturer's instructions and shall maintain the existing building warrantee as applicable.

Flexible boots shall be provided at all roofing penetrations in accordance with the roofing manufacturer's instruction.

Touch up blemishes in hot dip finish with zinc rich paint, supply by installer.

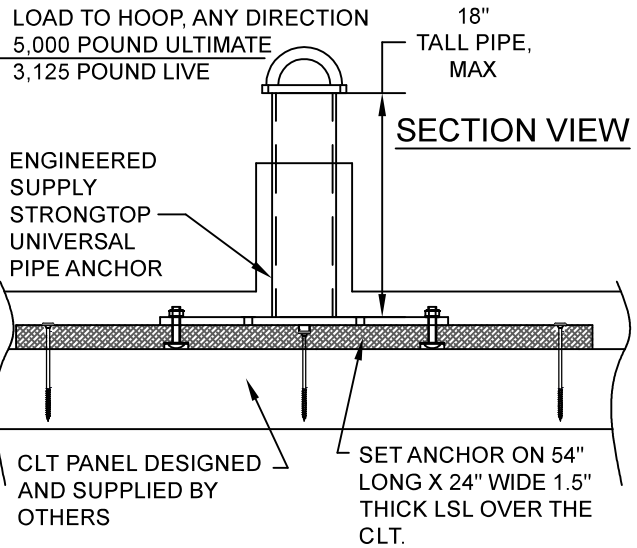

ROOFING FLASHING PER ROOFING MANUFACTURER'S INSTRUCTION

ALL METALS TO BE HOT DIPPED GALVANIZED UNLESS NOTED OTHERWISE

FASTENERS, WOOD PRODUCTS, AND ROOFING BY OTHERS, UNLESS NOTED OTHERWISE, TYPICAL.

THIS DETAIL IS COMPLIANT WITH ANSI Z359.18-T, IBC, AISC, AWS, NDS, IWCA I-14.1, OSHA, AND CAL-OSHA.

THIS DETAIL SHOP TESTS ELASTICALLY AT 5,000 POUNDS FORCE APPLIED AT THE TOP OF HOOP.

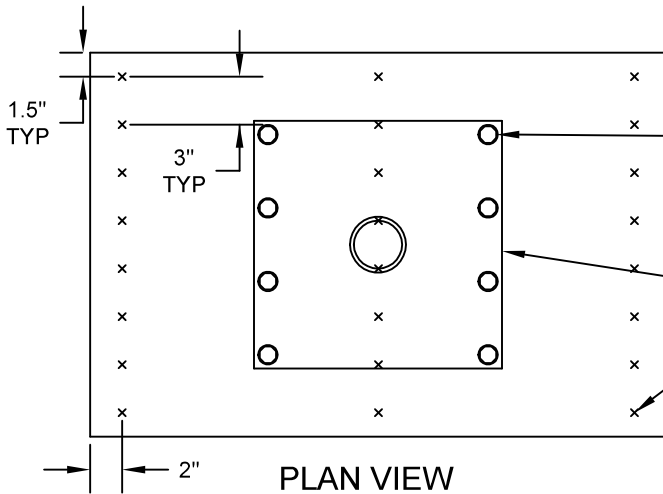

8- 1/2" DIAMETER CARRIAGE BOLTS WITH LOKTITE RED ON JAM NUT TOP AND FENDER WASHER BOTTOM. 2" DIAMETER x 0.5" DEEP COUNTERBORE BOTTOM OF LVL AT CARRIAGE BOLT LOCATIONS.

ENGINEERED SUPPLY STRONGTOP UNIVERSAL PIPE ANCHOR, CENTERED

24- U2 CONSTRUCTION FASTENERS FROM LSL PLINTH INTO CLT (3- ROWS OF 8- EACH) COUNTERSINK HEAD 1/2" BELOW ANCHOR. 4", 5", OR 6" LONG BASED ON AVAILABLE CLT THICKNESS.

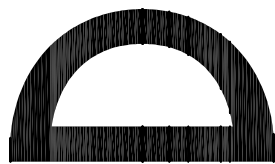

ENGINEERED SUPPLY

201 2ND AVE SOUTH
BAYPORT, MINNESOTA 55003

651-439-0932
ENGINEEREDSUPPLY.COM

STRONGTOP™

Permanent Suspended Maintenance

ES P/N 901002-518g

GENERAL INSTALLATION DETAIL,
CLT PANEL ATTACHMENT,
UNIVERSAL PIPE ANCHOR

SIZE
8.5x11

FSCM NO.
-

DWG NO.
901002-518g

THIS DRAWING AND THE DESIGN SHOWN IS THE SOLE PROPERTY OF ENGINEERED SUPPLY.

SCALE 1" = 1'-0"

SHEET 1 of 1

REVISIONS				
ZONE	REV	DESCRIPTION	DATE	APPROVED
-	2	ISSUED FOR USE (10 YEAR UPDATE)	11/14/2023	APG

GENERAL NOTES

The installation contractor is solely responsible for site safety. Site visits by Engineered Supply do not include review of the contractor's safety precautions. **BASE MATERIALS** Base material shall be structural building steel with a yield strength between 36 ksi and 50 ksi or equal with written approval from Engineered Supply.

Installation drawings documenting the base materials and welds shall be provided by others and shall be reviewed by an experienced site licensed engineer for all tieback and rope descent systems, or by a competent qualified person for all fall protection systems.

ANCHOR WELDING Anchor welds shall consist of 3/16", 1/4" or 5/16" leg length field placed fillet welds.

Anchor throat thickness varies based on pipe height, and shall be determined by the base material for the specific installation.

Anchor welds shall be made with E70xx material, or equal weld filler material. All welds shall be in strict accordance to AWS requirements, including welds completed by a certified welder and qualified process with inspection under a Certified Welding Inspector (CWI).

Field welds shall be prepared and field touch up painted with zinc rich paint by others.

INSPECTION AND TRAINING All fall protection and suspended maintenance equipment shall be selected or designed by others.

Usage shall comply with the current version of the ANSI IWCA I14.1. Systems users to inspect all equipment prior to each use, including all visible attachment points, locks, and pins to ensure all equipment is in safe working order. All users shall be trained on proper use of the equipment, as well as knowing and complying with OSHA, ANSI and other pertinent life safety regulations.

Equipment for rope descent and tie back use shall be initially load tested under the direction of a licensed engineer and annually inspected by a competent qualified person. Equipment shall be re-certified within 5 years

BUILDING ENVELOPE Installation and materials surrounding the anchor shall be designed by others in compliance with the applicable manufacturer's instructions and shall maintain the existing building warrantee as applicable. Flexible boots shall be provided at all roofing penetrations in accordance with the roofing manufacturer's instruction.



Touch up blemishes in hot dip finish with zinc rich paint, supply by installer.

ELECTRODES, PLATES, BRACES, STRUCTURAL STEEL, DECKING, AND ROOFING BY INSTALLER, UNLESS NOTED OTHERWISE, TYPICAL.

STOCKED IN 12", 14", 16", 18", 24", AND 30" PIPE HEIGHTS, THESE STOCKED PRODUCTS ARE COMPLIANT WITH ANSI Z359.18-T, IBC, AISC, AWS, IWCA I-14.1, OSHA, AND CAL-OSHA.

SPECIFICALLY NOTE THAT THE INFORMATION GIVEN ARE MINIMUMS FOR THE ANCHORAGE ATTACHMENT. THIS BASE MATERIAL IS REQUIRED TO BE FURTHER VERIFIED FOR THE APPLICABLE LOADS BY THE PROJECT ENGINEER FOR ROPE DESCENT AND TIEBACK, OR BY THE COMPETENT QUALIFIED PERSON FOR FALL PROTECTION.

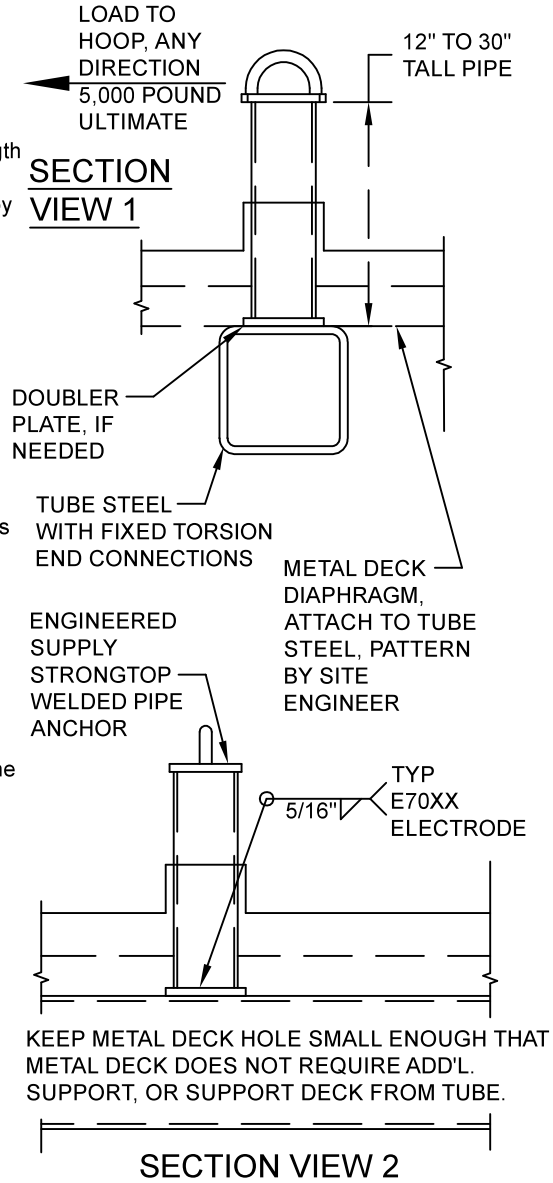
THIS ANCHORAGE CONNECTOR DETAIL SHOP TESTS ELASTICALLY AT 5,000 POUNDS FORCE APPLIED AT THE TOP OF HOOP, PERPENDICULAR TO HOOP.

ENGINEERED SUPPLY

201 2ND AVE SOUTH
BAYPORT, MINNESOTA 55003

651-439-0932
ENGINEEREDSUPPLY.COM

THIS DRAWING AND THE DESIGN SHOWN IS THE SOLE PROPERTY OF ENGINEERED SUPPLY.

STRONGTOP®
Permanent Suspended Maintenance

ES P/N 901004-502

GENERAL INSTALLATION DETAIL,
RECTANGULAR TUBE STEEL BEAM
ATTACHMENT, WELDED PIPE ANCHOR

SIZE 8.5x11	PATENT NO. D772040	DWG NO. 901004-502
SCALE 1" = 1'-0"		SHEET 1 of 1

REVISIONS				
ZONE	REV	DESCRIPTION	DATE	APPROVED
-	2	ISSUED FOR USE (10 YEAR UPDATE)	11/15/2023	APG

GENERAL NOTES

The installation contractor is solely responsible for site safety. Site visits by Engineered Supply do not include review of the contractor's safety precautions. Installation drawings documenting the base materials and anchor bolts shall be provided by others and shall be reviewed by an experienced licensed engineer for all tieback and rope descent systems, or by a competent qualified person for all fall protection systems.

BASE MATERIALS Base material shall be capable of supporting the loads shown in accordance with the current applicable codes for the project location.

ANCHOR BOLTS All anchors shall be installed in strict accordance with the anchor manufacturer's instruction. Anchor fasteners shall be torqued with a calibrated wrench in accordance to the anchor manufacturer's literature.

INSPECTION AND TRAINING

All fall protection and suspended maintenance equipment shall be selected or designed by others. Usage shall comply with the current version of the ANSI IWCA 114.1. Systems users to inspect all equipment prior to each use, including all visible attachment points, locks, and pins to ensure all equipment is in safe working order. All users shall be trained on proper use of the equipment, as well as knowing and complying with OSHA, ANSI and other pertinent life safety regulations. Equipment for rope descent and tie back use shall be initially load tested under the direction of a licensed engineer and annually inspected by a competent qualified person. Equipment shall be re-certified within 5 years.

BUILDING ENVELOPE Installation and materials surrounding the anchor shall be designed by others in compliance with the applicable manufacturer's instructions and shall maintain the existing building warrantee as applicable. Flexible boots shall be provided at all roofing penetrations in accordance with the roofing manufacturer's instruction.

KEYED NOTES

- A.** ENGINEERED SUPPLY STRONGTOP WIDE PLATE ANCHOR.
- B.** CONCRETE MASONRY WALL. 2,000 PSI MINIMUM COMPRESSIVE STRENGTH GROUT FILLED. 8" MINIMUM NOMINAL THICKNESS. RUNNING BOND, WITH JOINT REINFORCING, FULL MORTAR ALL BED JOINTS.
- C.** 3/4" DIAMETER 18-8 STAINLESS STEEL THROUGH BOLT WITH PLATE WASHER AND NUT ON BACK SIDE. USE LOCTITE. TORQUE TO 100 FTLB.

SPECIFICALLY NOTE THAT THE MINIMUM GIVEN INFORMATION INDICATES NECESSARY SUBSTRATE FOR THE FASTENERS. THIS BASE MATERIAL IS REQUIRED TO BE FURTHER VERIFIED FOR THE APPLICABLE LOADS BY THE PROJECT ENGINEER FOR ROPE DESCENT AND TIEBACK, OR BY THE COMPETENT QUALIFIED PERSON FOR FALL PROTECTION.

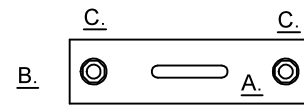
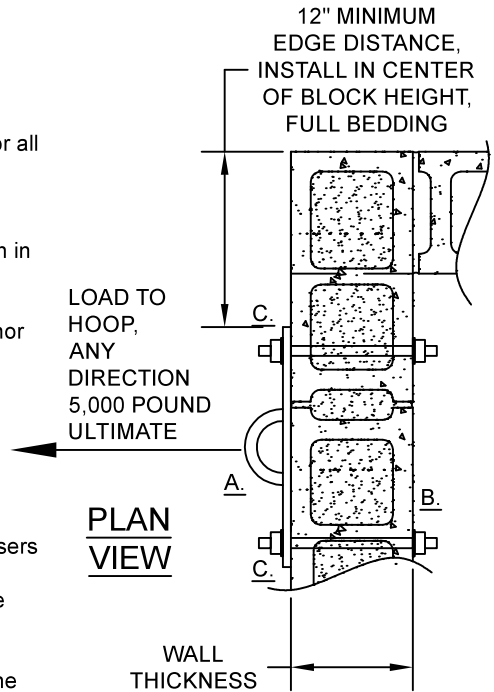

ELEVATION VIEW

THIS DETAIL SHOP TESTS ELASTICALLY AT 5,000 POUNDS FORCE APPLIED AT THE TOP OF HOOP.

THIS DETAIL IS COMPLIANT WITH ANSI Z359.18-T, IBC, AISC, AWS, ACI, IWCA I-14.1, OSHA, AND CAL-OSHA.

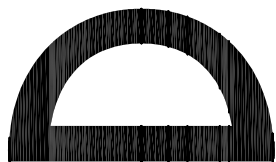

ENGINEERED SUPPLY

201 2ND AVE SOUTH
BAYPORT, MINNESOTA 55003

651-439-0932
ENGINEEREDSUPPLY.COM

STRONGTOP™

Permanent Suspended Maintenance

ES P/N 902002-501

GENERAL INSTALLATION DETAIL,
CONCRETE MASONRY WALL
ATTACHMENT, WIDE PLATE ANCHOR

SIZE

8.5x11

-

DWG NO.

902002-501

THIS DRAWING AND THE DESIGN SHOWN IS THE SOLE PROPERTY OF ENGINEERED SUPPLY.

SCALE 1" = 1'-0"

SHEET 1 of 1

REVISIONS				
ZONE	REV	DESCRIPTION	DATE	APPROVED
-	2	ISSUED FOR USE (10 YEAR UPDATE)	11/20/2023	APG

GENERAL NOTES

The installation contractor is solely responsible for site safety. Site visits by Engineered Supply do not include review of the contractor's safety precautions.

BASE MATERIALS Base material shall be bar joists with a yield strength between 36 ksi and 50 ksi and thickness greater than 1/8" or equal with written approval from Engineered Supply.

Installation drawings documenting the base materials and welds shall be provided by others and shall be reviewed by an experienced site licensed engineer for all tieback and rope descent systems, or by a competent qualified person for all fall protection systems.

ANCHOR WELDING Anchor welds shall consist of 3/16", 1/4" or 5/16" leg length field placed fillet welds.

Anchor throat thickness varies based on pipe height, and shall be determined by the base material for the specific installation.

Anchor welds shall be made with E70xx material, or equal weld filler material. All welds shall be in strict accordance to AWS requirements, including welds completed by a certified welder and qualified process with inspection under a Certified Welding Inspector (CWI).

Field welds shall be prepared and field touch up painted with zinc rich paint by others.

INSPECTION AND TRAINING All fall protection and suspended maintenance equipment shall be selected or designed by others.

Usage shall comply with the current version of the ANSI IWCA I14.1. Systems users to inspect all equipment prior to each use, including all visible attachment points, locks, and pins to ensure all equipment is in safe working order. All users shall be trained on proper use of the equipment, as well as knowing and complying with OSHA, ANSI and other pertinent life safety regulations.

Equipment for rope descent and tie back use shall be initially load tested under the direction of a licensed engineer and annually inspected by a competent qualified person. Equipment shall be re-certified within 5 years

BUILDING ENVELOPE Installation and materials surrounding the anchor shall be designed by others in compliance with the applicable manufacturer's instructions and shall maintain the existing warrantee as applicable.

Flexible boots shall be provided at all roofing penetrations in accordance with the roofing manufacturer's instruction.

Touch up blemishes in hot dip finish with zinc rich paint, supply by installer.

SPECIFICALLY NOTE THAT THE INFORMATION GIVEN ARE MINIMUMS FOR THE ANCHORAGE ATTACHMENT. THIS BASE MATERIAL IS REQUIRED TO BE FURTHER VERIFIED FOR THE APPLICABLE LOADS BY THE PROJECT ENGINEER FOR ROPE DESCENT AND TIEBACK, OR BY THE COMPETENT QUALIFIED PERSON FOR FALL PROTECTION.

ELECTRODES, ANGLE BRACE, STRUCTURAL STEEL, AND ROOFING BY INSTALLER, UNLESS NOTED OTHERWISE, TYPICAL.

STOCKED IN 12", 14", 16", AND 18" PIPE HEIGHTS, THESE STOCKED PRODUCTS ARE COMPLIANT WITH ANSI Z359.18-T, IBC, AISC, AWS, SJI, IWCA I-14.1, OSHA, AND CAL-OSHA.

SECTION VIEW 1

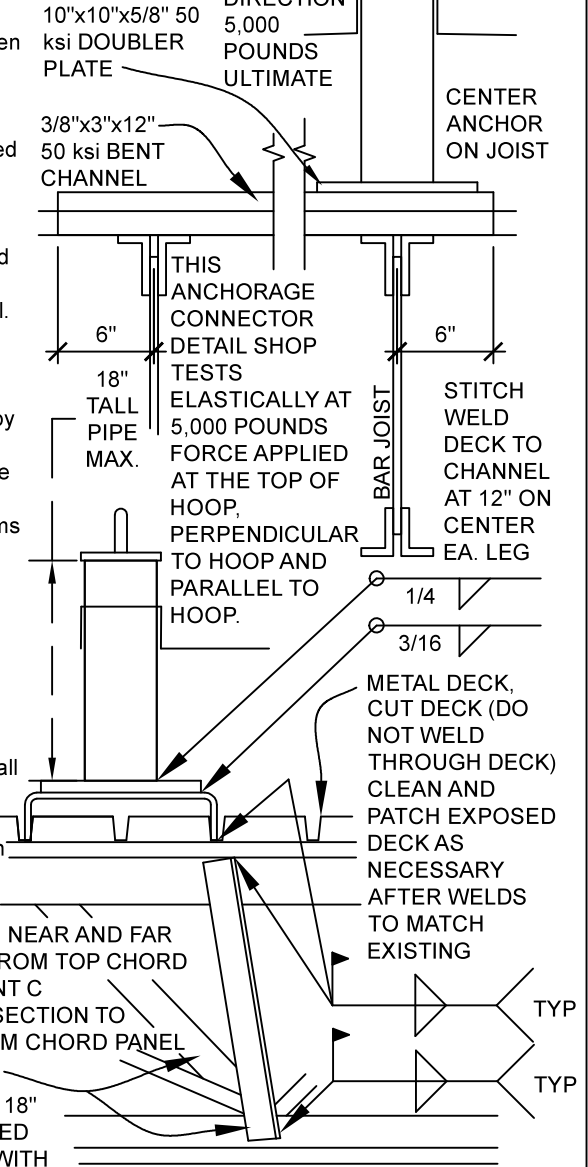

SECTION VIEW 2

 <p>ENGINEERED SUPPLY</p>	<p>STRONGTOP® Permanent Suspended Maintenance</p>		
	<p>ES P/N 901004-502</p>		
<p>GENERAL INSTALLATION DETAIL, STEEL BAR JOIST ATTACHMENT, WELDED PIPE ANCHOR</p>			
201 2ND AVE SOUTH BAYPORT, MINNESOTA 55003	651-439-0932 ENGINEEREDSUPPLY.COM	SIZE 8.5x11	PATENT NO. D772040
		DWG NO. 901004-502	
THIS DRAWING AND THE DESIGN SHOWN IS THE SOLE PROPERTY OF ENGINEERED SUPPLY.		SCALE 1" = 1'-0"	SHEET 1 of 1

REVISIONS				
ZONE	REV	DESCRIPTION	DATE	APPROVED
-	2	ISSUED FOR USE (10 YEAR UPDATE)	11/20/2023	APG

GENERAL NOTES

The installation contractor is solely responsible for site safety. Site visits by Engineered Supply do not include review of the contractor's safety precautions.

BASE MATERIALS Base material shall be structural steel wide flange beams with a yield strength between 36 ksi and 50 ksi and thickness greater than 1/8" or equal with written approval from Engineered Supply.

Installation drawings documenting the base materials and welds shall be provided by others and shall be reviewed by an experienced site licensed engineer for all tieback and rope descent systems, or by a competent qualified person for all fall protection systems.

ANCHOR WELDING Anchor welds shall consist of 3/16", 1/4" or 5/16" leg length field placed fillet welds.

Anchor throat thickness varies based on pipe height, and shall be determined by the base material for the specific installation.

Anchor welds shall be made with E70xx material, or equal weld filler material. All welds shall be in strict accordance to AWS requirements, including welds completed by a certified welder and qualified process with inspection under a Certified Welding Inspector (CWI).

Field welds shall be prepared and field touch up painted with zinc rich paint by others.

INSPECTION AND TRAINING All fall protection and suspended maintenance equipment shall be selected or designed by others.

Usage shall comply with the current version of the ANSI IWCA I14.1. Systems users to inspect all equipment prior to each use, including all visible attachment points, locks, and pins to ensure all equipment is in safe working order. All users shall be trained on proper use of the equipment, as well as knowing and complying with OSHA, ANSI and other pertinent life safety regulations.

Equipment for rope descent and tie back use shall be initially load tested under the direction of a licensed engineer and annually inspected by a competent qualified person. Equipment shall be re-certified within 5 years

BUILDING ENVELOPE Installation and materials surrounding the anchor shall be designed by others in compliance with the applicable manufacturer's instructions and shall maintain the existing building warrantee as applicable. Flexible boots shall be provided at all roofing penetrations in accordance with the roofing manufacturer's instruction.

Touch up blemishes in hot dip finish with zinc rich paint, supply by installer.

SPECIFICALLY NOTE THAT THE INFORMATION GIVEN ARE MINIMUMS FOR THE ANCHORAGE ATTACHMENT. THIS BASE MATERIAL IS REQUIRED TO BE FURTHER VERIFIED FOR THE APPLICABLE LOADS BY THE PROJECT ENGINEER FOR ROPE DESCENT AND TIEBACK, OR BY THE COMPETENT QUALIFIED PERSON FOR FALL PROTECTION.

ELECTRODES, STRUCTURAL STEEL, AND ROOFING BY INSTALLER, UNLESS NOTED OTHERWISE, TYPICAL.

STOCKED IN 12", 14", 16", AND 18" PIPE HEIGHTS, THESE STOCKED PRODUCTS ARE COMPLIANT WITH ANSI Z359.18-T, IBC, AISC, AWS, SJI, IWCA I-14.1, OSHA, AND CAL-OSHA.

SECTION VIEW 1

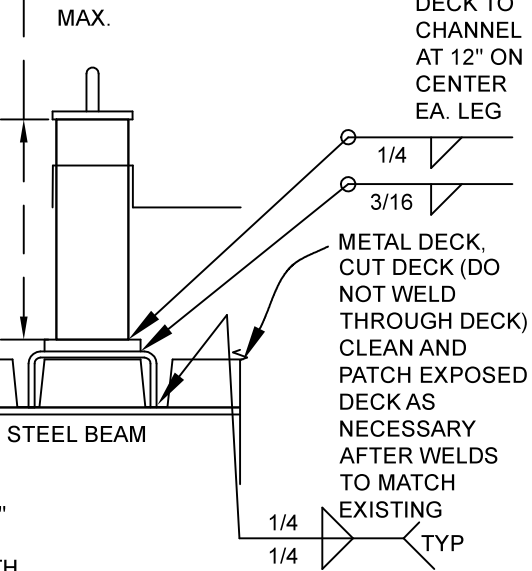
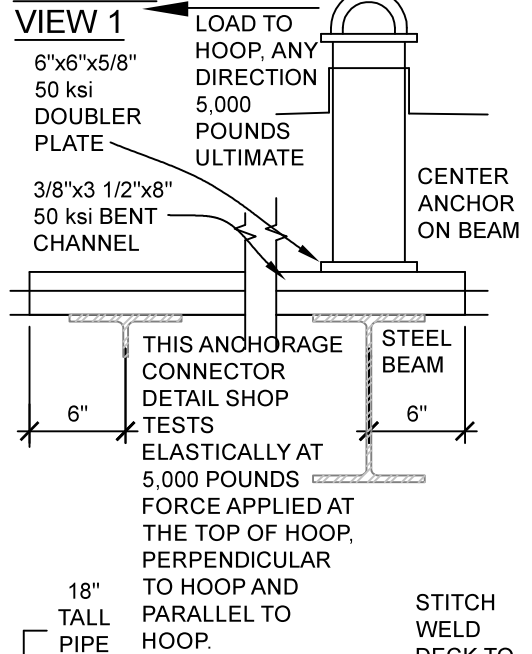

SECTION VIEW 2

 <p>ENGINEERED SUPPLY</p>	<p>STRONGTOP® Permanent Suspended Maintenance</p>		
	<p>ES P/N 901004-503</p>		
<p>GENERAL INSTALLATION DETAIL, STEEL BEAM WITH 3" METAL ROOF DECK, WELDED PIPE ANCHOR</p>			
201 2ND AVE SOUTH BAYPORT, MINNESOTA 55003	651-439-0932 ENGINEEREDSUPPLY.COM	SIZE 8.5x11	PATENT NO. D772040
		DWG NO. 901004-503	
THIS DRAWING AND THE DESIGN SHOWN IS THE SOLE PROPERTY OF ENGINEERED SUPPLY.		SCALE 1" = 1'-0"	SHEET 1 of 1

REVISIONS				
ZONE	REV	DESCRIPTION	DATE	APPROVED
-	2	ISSUED FOR USE (10 YEAR UPDATE)	11/20/2023	APG

GENERAL NOTES

The installation contractor is solely responsible for site safety. Site visits by Engineered Supply do not include review of the contractor's safety precautions. Installation drawings documenting the base materials and anchor bolts shall be provided by others and shall be reviewed by an experienced licensed engineer for all tieback and rope descent systems, or by a competent qualified person for all fall protection systems.

BASE MATERIALS Base material shall be capable of supporting the loads shown in accordance with the current applicable codes for the project location.

ANCHOR BOLTS
All anchors shall be installed in strict accordance with the anchor manufacturer's instruction.
Anchor fasteners shall be torqued with a calibrated wrench in accordance to the anchor manufacturer's literature (40 ftlb).

INSPECTION AND TRAINING All fall protection and suspended maintenance equipment shall be selected or designed by others.
Usage shall comply with the current version of the ANSI IWCA I14.1. Systems users to inspect all equipment prior to each use, including all visible attachment points, locks, and pins to ensure all equipment is in safe working order. All users shall be trained on proper use of the equipment, as well as knowing and complying with OSHA, ANSI and other pertinent life safety regulations.
Equipment for rope descent and tie back use shall be initially load tested under the direction of a licensed engineer and annually inspected by a competent qualified person. Equipment shall be re-certified within 5 years.

BUILDING ENVELOPE Installation and materials surrounding the anchor shall be designed by others in compliance with the applicable manufacturer's instructions and shall maintain the existing building warrantee as applicable.
Flexible boots shall be provided at all roofing penetrations in accordance with the roofing manufacturer's instruction.

LOAD TO HOOP, ANY DIRECTION
5,000 POUND ULTIMATE

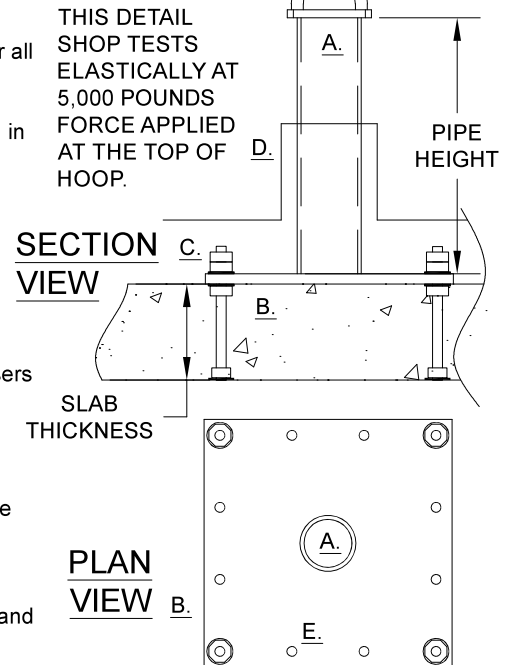

KEYED NOTES

- A. ENGINEERED SUPPLY STRONGTOP UNIVERSAL PIPE ANCHOR, 24" MAXIMUM PIPE HEIGHT.
- B. CONCRETE SLAB, 3,000 PSI MINIMUM COMPRESSIVE STRENGTH, 4" MINIMUM THICKNESS.
- C. 304 STAINLESS STEEL EMBED BOLT WITH LOCTITE. SUPPLY BY ES WITH ANCHOR UNLESS NOTED OTHERWISE. NAIL FOOT TO FORM.
- D. ROOFING FLASHING PER ROOFING MANUFACTURER'S INSTRUCTION. SUPPLY BY INSTALLER UNLESS NOTED OTHERWISE.
- E. ACCEPTABLE TO LEAVE REMAINING HOLES OPEN.

SPECIFICALLY NOTE THAT THE 4" MINIMUM SLAB THICKNESS INDICATES NECESSARY SLAB THICKNESS FOR THE GIVEN HARDWARE. THIS BASE MATERIAL IS REQUIRED TO BE FURTHER VERIFIED FOR THE APPLICABLE LOADS BY THE PROJECT ENGINEER FOR ROPE DESCENT AND TIEBACK, OR BY THE COMPETENT QUALIFIED PERSON FOR FALL PROTECTION.

THIS DETAIL IS COMPLIANT WITH ANSI Z359.18-T, IBC, AISC, AWS, ACI, IWCA I-14.1, OSHA, AND CAL-OSHA.

 <p>ENGINEERED SUPPLY</p>	<p>STRONGTOP® Permanent Suspended Maintenance</p>		
	<p>ES P/N 901002-512</p>		
<p>GENERAL INSTALLATION DETAIL, CAST IN CONCRETE SLAB ATTACHMENT, UNIVERSAL PIPE ANCHOR</p>			
201 2ND AVE SOUTH BAYPORT, MINNESOTA 55003	651-439-0932 ENGINEEREDSUPPLY.COM	SIZE 8.5x11	PATENT NO. D772040
<p>THIS DRAWING AND THE DESIGN SHOWN IS THE SOLE PROPERTY OF ENGINEERED SUPPLY.</p>		DWG NO. 901002-512	SCALE 1" = 1'-0"
		SHEET 1 of 1	